

ELEVATORS 101

WHAT YOU NEED TO KNOW

William Redmond, QEI-S 141/CEI 238 -
Chief Elevator Inspector
Broward County Building Code Division



Program Overview

- ▶ Conformance to the Florida Building Code and the Florida State Statutes through review of all construction plans for new and altered elevating devices.
- ▶ Safety for elevating devices through mandated enforcement by Certified Elevator Inspectors per [Chapter 399](#) of the Florida State Statutes, [Chapter 61C5](#) of the Florida Administrative Code, and Chapter 30 of the [Florida Building Code](#).
- ▶ Complete inspections associated with Alterations, New Installations, Complaints and Accidents for elevating devices.
- ▶ Timely coordination with fire, police, paramedics and other emergency responders on accidents involving elevating devices.



Agenda

- ▶ Certificate of Operation for elevating devices and device requirements
- ▶ Renewing Certificate of Operations and requirements
- ▶ Importance of annual inspections
- ▶ Obtaining inspection results
- ▶ Violations and Owner Responsibility
- ▶ Role of the Elevator Maintenance Companies and Required Upgrades
- ▶ Variance Process
- ▶ Change of Record and maintaining updated contact information



Elevating Devices

- ▶ Elevators
- ▶ Wheelchair Lifts
- ▶ Stairway Lifts
- ▶ Escalators
- ▶ Moving Walks
- ▶ Dumbwaiters
- ▶ Limited Use, Limited Access Devices (LULA)



Florida Statutes & Rules



Press Esc to exit full screen



2023 Florida Statutes

Elevator Safety

Chapter 399

Bureau of Elevator Safety
DIVISION OF HOTELS AND RESTAURANTS
Department of Business and Professional Regulation

www.MyFloridaLicense.com/dbpr/elevator-safety/

2023 July 1



Florida Elevator Safety Code

Administrative Rules

September 1, 2021

CHAPTER 61C-5
Florida Administrative Code
FLORIDA ELEVATOR SAFETY CODE



Florida Building Code

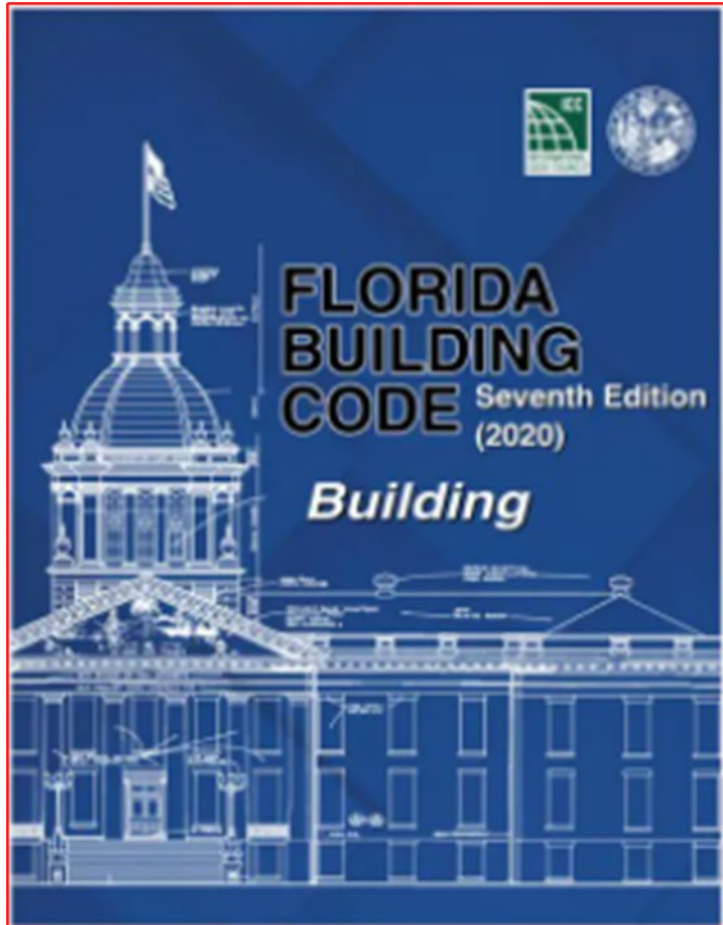

THE FLORIDA BUILDING CODE BROWARD COUNTY AMENDMENTS

Broward County Amendments
To the Florida Building Code 7th Edition (2020)
Effective Date: December 31, 2020
Adopted on October 8, 2020
With Amendments Effective through March 22, 2021

IN ORDER TO RECEIVE AMENDMENTS TO THIS CODE,
NOTIFY THIS OFFICE
(954) 765-4500 Ext. 9891/9885
FOR A DIGITAL COPY VISIT:
<https://www.broward.org/CodeAppeals/Pages/AmendmentsInterpretations>

municode

Municipal Code Corporation P.O. Box 2235 Tallahassee, FL 32316
info@municode.com 800.262.2633 www.municode.com

Supp 1, FBC 7th Edition, 2020



Elevator Safety Codes

ASME A17.1-2019/CSA B44:19
(Revision of ASME A17.1-2016/CSA B44-16)

Safety Code for Elevators and Escalators

Includes Requirements for Elevators, Escalators, Dumbwaiters, Moving Walks, Material Lifts, and Dumbwaiters With Automatic Transfer Devices

AN AMERICAN NATIONAL STANDARD



ASME A18.1-2020
(Revision of ASME A18.1-2017)

Safety Standard for Platform Lifts and Stairway Chairlifts

AN AMERICAN NATIONAL STANDARD



ASME A17.3-2020
(Revision of ASME A17.3-2017)

Safety Code for Existing Elevators and Escalators

Includes Requirements for Electric and Hydraulic Elevators and Escalators

AN AMERICAN NATIONAL STANDARD



System to Monitor and Prevent Automatic Operation of the Elevator With Faulty Door Contact Circuits (Door Position Monitor - DPM)

- ▶ Required on all existing Elevator on or before August 1, 2025
- ▶ Existing Traction Elevators were required to have this per 1996 edition
- ▶ Existing Hydraulic Elevators were required to have this per 2000 edition
- ▶ Elevators installed or altered after these editions should already have this
- ▶ 1996 edition was effective in Florida October 4, 2000
- ▶ 2000 edition was effective in Florida October 1, 2005
- ▶ All traction elevators with the seven (7) digit BCID should already comply
- ▶ All hydraulic elevator with the seven (7) digit BCID starting with 06-00001 or higher should already comply



(I) The effective date for Part 3.10.12 of ASME A17.3-2020 is changed from December 31, 2023, to August 1, 2025. All elevators must comply with Part 3.10.12 beginning August 1, 2025.

(II) The effective date for Parts 3.8.5, 3.10.13, 3.10.14, 3.13.1, and 3.13.2 of ASME A17.3-2020 is changed from December 31, 2023, until August 1, 2028. All elevators must comply with Parts 3.8.5, 3.10.13, 3.10.14, 3.13.1, and 3.13.2 beginning August 1, 2028.

[96] **Rule 210.15 System to Monitor and Prevent Automatic Operation of the Elevator With Faulty Door Contact Circuits**

2.26.5 System to Monitor and Prevent Automatic Operation of the Elevator With Faulty Door Contact Circuits

**SECTION 3.26
OPERATING DEVICES AND CONTROL
EQUIPMENT**

**3.26.1 Operating Devices and Control
Equipment**

Operating devices and control equipment shall conform to 2.26, except as modified by the following:

**SECTION 3.13
ASCENDING CAR OVERSPEED AND UNINTENDED
CAR MOVEMENT PROTECTION**

3.13.1 Ascending Car Overspeed Protection

3.8.5 Emergency Brake

**3.10.13 Ascending Car Overspeed Protection
Device**

3.13.2 Unintended Car Movement Protection

3.10.14 Unintended Car Movement Device



ASME Elevator Safety Code A17.3-2015, Safety Code for Existing Elevators and Escalators

Part of this new Safety Code includes:

- Section 3.10 Operating Devices and Control Equipment
- Requirement 3.10.12 System to Monitor and Prevent Automatic Operation of the Elevator with Faulty Door Contact Circuits

All conveyances licensed by the State of Florida Bureau of Elevator Safety, including those located within the 5 contracted jurisdictions must be in compliance of the above Code by December 31, 2023. The Bureau of Elevator Safety encourages all owners of conveyances licensed by the State of Florida or any of its 5 Contracted Jurisdictions to contact your Elevator Company to discuss what your conveyances will need in order to comply with this section of A17.3-2015.

Effective Date	Elevator Codes	Starting License Number
October 1, 2005	2nd Ed. (2004) Florida Building Code ASME A17.1-2000 ASME A17.3-1996 ASME A18.1-1999, with A18.1a-2001	89072
October 4, 2000	ASME A17.1-1996, with A17.1a-1997 & A17.1b-1998 ASME A90.1-1992 NFPA 70-1999	**59628





ASME A17.1-2000

SAFETY CODE FOR ELEVATORS

SECTION 2.19 ASCENDING CAR OVERSPEED AND UNINTENDED CAR MOVEMENT PROTECTION

This edition was approved by the American National Standards Institute on October 16, 2000. It was issued on March 23, 2001 and is effective as of March 23, 2002.

October 1, 2005

2nd Ed. (2004) Florida Building Code
ASME A17.1-2000
ASME A17.3-1996
ASME A18.1-1999, with A18.1a-2001



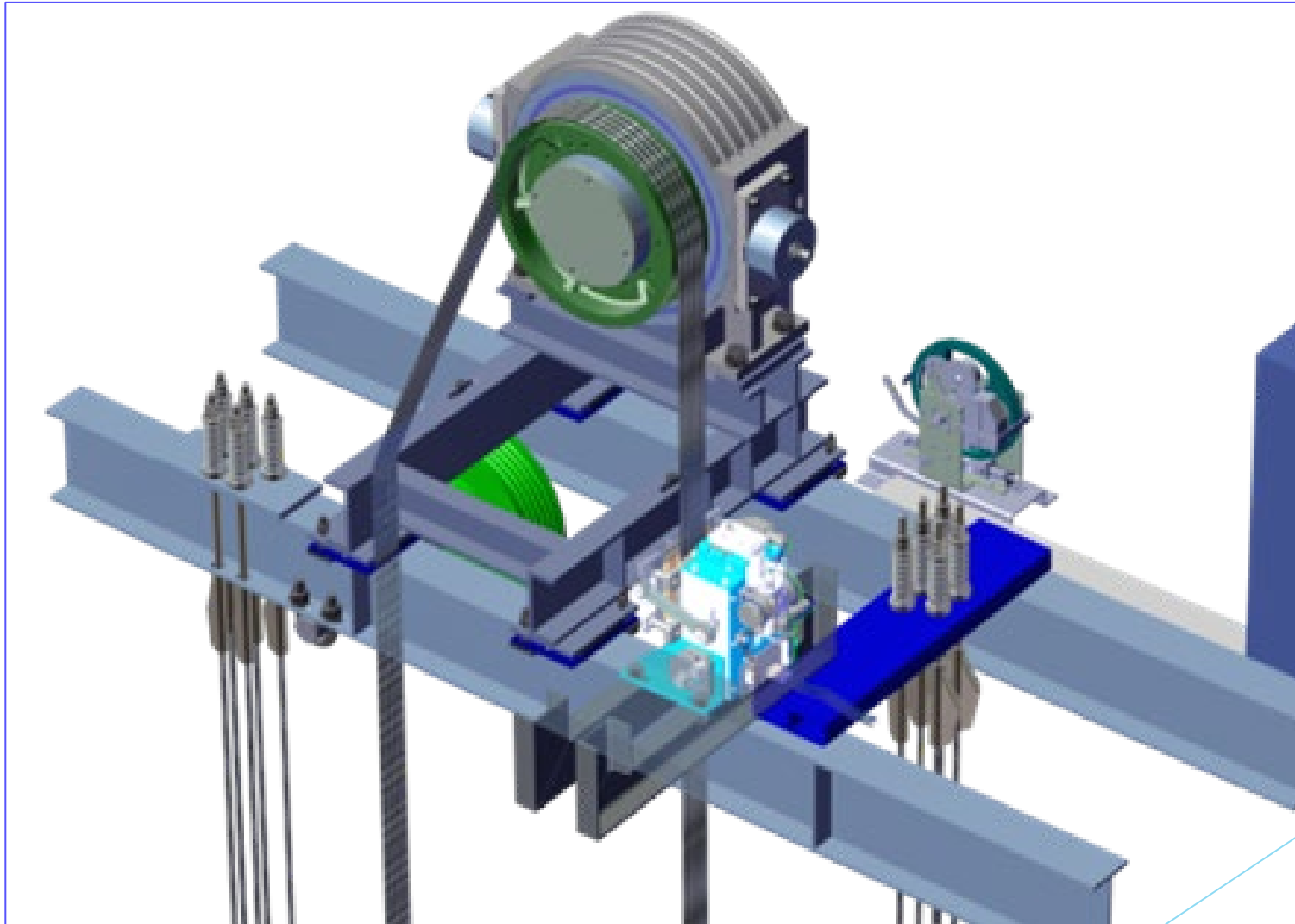

2.13.5 Reopening Device(s) for Power-Operated Horizontally Sliding Doors and Gates

(19)

Figure S-13 Cylindrical Targets (2.13.5.3)

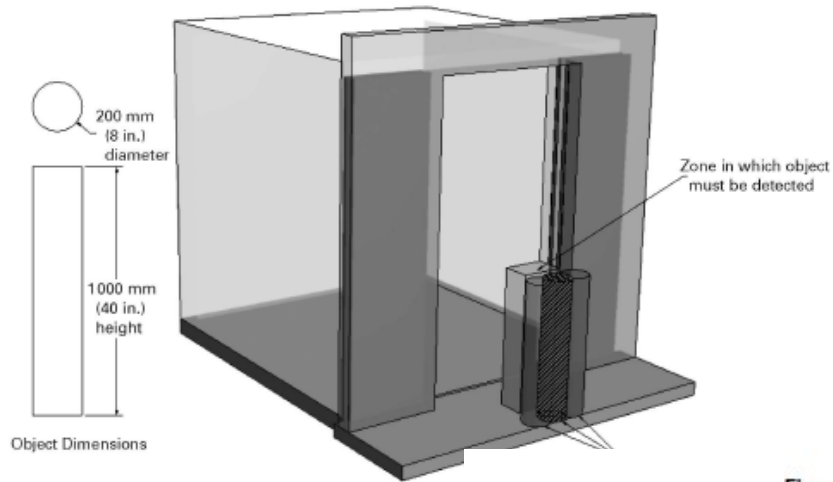

Figure S-14 Prismatic Targets (2.13.5.4.1)

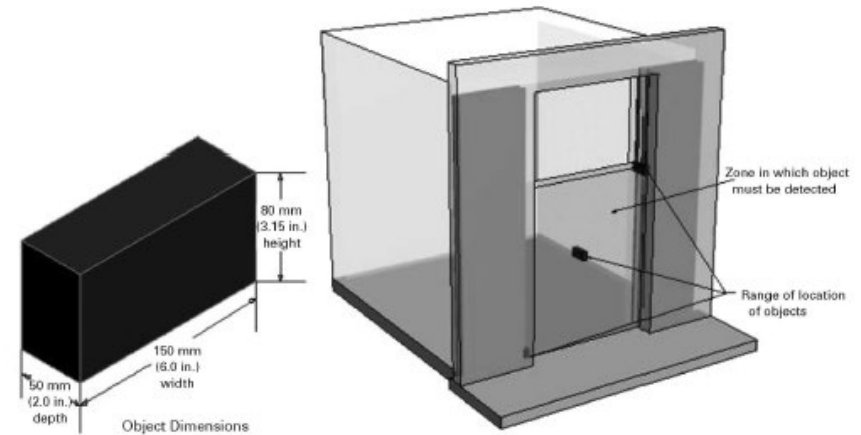
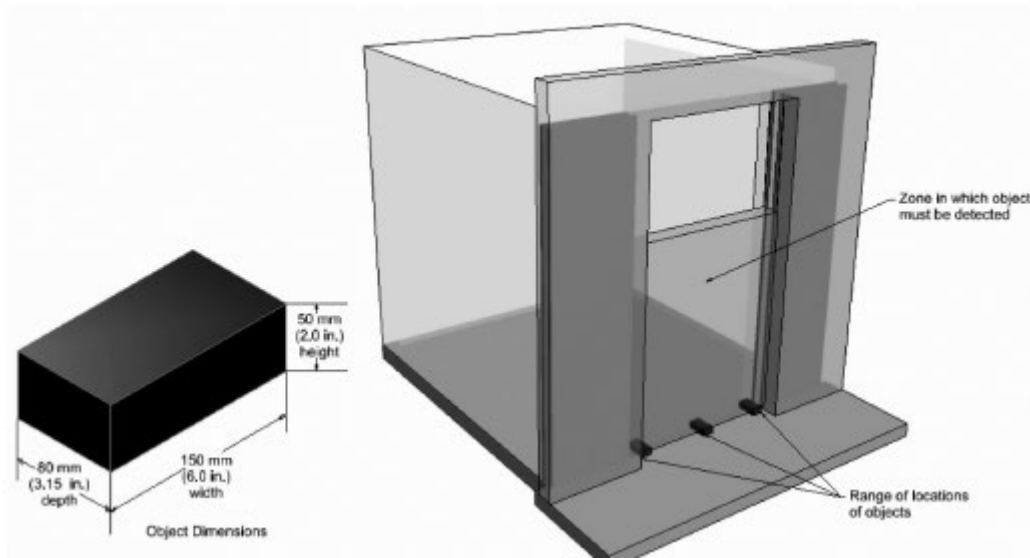
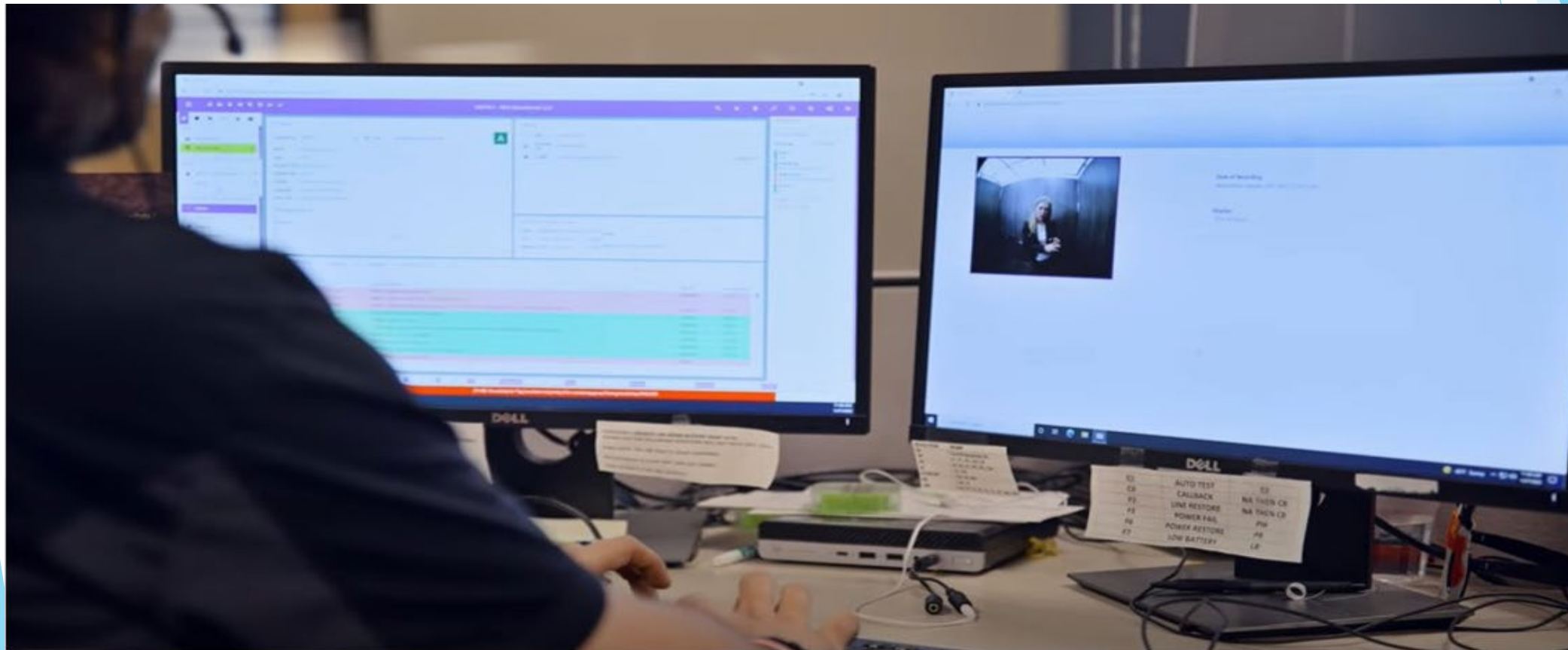

Figure S-15 Prismatic Targets (2.13.5.4.2)



2.27.1 Car Emergency Signaling Devices

- (19) **2.27.1.1 Emergency Communications.** The two-way communications shall conform to 2.27.1.1.1 through 2.27.1.1.6.



Certificate of Operation



Resilient Environment Department
BUILDING CODE DIVISION
Elevator Section
2307 West Broward Boulevard | Suite 300 - Fort Lauderdale, FL 33312

FOR EMERGENCIES CALL 911

Elevator Type: Traction Passenger
BCID#: 07-00454 Landings: 4 Capacity: 3500
This is to certify that the elevator located at the following address:

Per FS399.02(5)(b), the elevator owner is responsible for the safe operation, proper maintenance, and inspection and correction of code deficiencies of the elevator.

Elevator Type: Traction
BCID#: 07-00454

Expiration Date: 08/01/2023

Last Inspection Date: 08/13/2021

has complied with Florida Statute 399 and is authorized to operate the elevator bearing the above BCID number.

Per FS399.02(5)(b), the elevator owner is responsible for the safe operation, proper maintenance, and inspection and correction of code deficiencies of the elevator.

Notify the building owner or property management company if the device is not functioning properly

CERTIFICATE OF OPERATION

This certificate shall be framed in metal with a clear plastic cover and shall be posted inside the elevator or plainly visible from the dumbwaiter or escalator.

AW Real Estate Management, LLC
11780 US Highway One, Suite 305
North Palm Beach, FL 33408

Expiration Date: 08/01/2023

Last Inspection Date: 08/13/2021

Important Notice

The Certificate of Elevator Operation is valid for a period of one year unless suspended or revoked. Florida Statute 399 requires that a current Elevator Operation certificate be posted inside each elevator.



NO SMOKING / NO FUMAR

Section 823.12 F.S., Smoking in elevators is unlawful, - It is unlawful for any person to possess any ignited tobacco product or other ignited substance while present in an elevator. Any person who violates this section is guilty of a misdemeanor of the second degree punishable as provided in S.775.082 or S.775.083, F.S



Last Inspection Date Sticker

Broward County Elevator Last Inspection Date



Inspected by: _____

Inspection Date: _____



Certificate of Operation

- ▶ License required by Florida Statute 399 that allows for the operation of elevating devices.
- ▶ Certificate of Operation is issued after the device passes an annual safety inspection, or if any violations were cited, they have been corrected within 90 days and all outstanding fees have been paid.
- ▶ All elevators in Broward County require a Certificate of Operation.
- ▶ Operation of an Elevator without a current Certificate of Operation is a violation of Florida Statute 399.



ELEVATOR CERTIFICATE OF OPERATION RENEWAL INVOICE



3668039

Management Co./Owner: **BC FACILITIES MAINTENANCE DIVISION
115 S ANDREWS AVE RM #501
FORT LAUDERDALE, FL 33301**

BCID # 33505
Date of Notice: **05/26/2022**
Amount Due: **\$100.00**
Expiration Date: **08/01/2022**
Last Approved Annual Inspection: **01/25/2022**

Phone Number: **(954) 831-6583** E-mail: **bleder@broward.org** Reference #: **3668039**

Payment is now due for renewal of the Certificate of Operation for the elevator identified by the BCID number above.
Certificates of operation shall be issued upon payment
only for conveyances having a current, approved annual inspection (FS399.07).

Building: **BROWARD COUNTY GCW PARKING DECK
1 N UNIVERSITY DR
PLANTATION, FL 33324**

Elevator Maint. Co.: **ORACLE ELEVATOR COMPANY
6500 NW 15 AVE SUITE 300
FORT LAUDERDALE, FL 33309
(954) 986-0991**

Fee Details	
05/02/22 Certificate of Operation Renewal Fee	\$100.00

A calculated Internet convenience fee of \$2.55 will be added if this renewal is paid online.

Use Web renewal ID: 74441770 to RENEW ONLINE, at:
www.broward.org/building

Or, mail bottom of form with credit card information or check payable to: **Broward County Board of Commissioners**
to this address: **2307 West Broward Boulevard | Suite 300 | Fort Lauderdale, FL 33312**

**Annual Inspections completed by a Broward County Elevator Inspector will be charged a separate fee of \$20.00 **

Please include a penalty of \$75.00 if payment is postmarked after July 31st, 2022.

Please use the space below to print any information that is missing or incorrect above.

	Name	Address	Phone Number
Building:			
Management Company / Owner:			
Email Address:			
Elevator Maint. Company:			

BCID #: **33505** Amount Due: **\$100.00** Select one: Visa Master Card Discover

Reference #: **3668039 - 1 - 1 - 05/26/22** Card Number _____

Please do not staple. Expiration Date _____ Security Code _____

Please do not send cash. Signature _____



3668039

Faxed copies will not be accepted.

Renewal Fees



Purpose of Annual Inspections

- ▶ FS 399.001 Purpose is to provide for the safety of life and limb and to promote public safety awareness.
- ▶ ASME A17.1 The purpose of this Code is to provide for the safety of life and limb, and to promote the public welfare.



Broward County, Florida**Building Code Services Division**

1 North University Drive, Box #302, Plantation, FL 33324-2038

Phone: 954-765-4508 Fax: 954-765-4785

e-mail: elevators@broward.org**ELEVATOR INSPECTION REPORT
and
VIOLATIONS TO BE CORRECTED**

Inspection Type: **Routine + Annual**
 Result: **Approved**
 Inspection Date: **04/27/2018**
 Inspector: **William Redmond CEI #238**
 (954) 658-1902

BCID: 33504 License
 Type: **Hydraulic Passenger**
 Floors: 4 Lbs.: 3500
 Route: **Area 09**

Building Name: **BROWARD COUNTY GCW ELEV - 4**
 Address: **1 N UNIVERSITY DR
 PLANTATION, FL 33324**

Person receiving this report:
Franklin Joseph

Maintenance Co.: **THYSSENKRUPP ELEVATOR**
 (954) 971-6500

CC #: 4035

DCF Front (lbs):
 DCF Back (lbs):
 NL (psi): 354
 FL (psi): 510
 REL (psi): 660
 Gov (E) (fpm):
 Gov (M) (fpm):
 Slide (in):
 BT (ft/lb):
 Step/Skirt Index:

Violations: NONE
Additional Comments:
 \$20 inspection fee due.

Florida Statutes - This device:

Complies: Section 399.15
 Regional emergency elevator
 access/fire key requirements
Complies: Section 553.509
 Alternate power requirements

NOTICE TO ELEVATOR OWNER

The violations noted must be corrected and Broward County Building Code Services Division - Elevator Section notified of compliance within 90 DAYS from the date of this inspection. Any elevator owner who fails to comply with this order within 90 days is subject to an administrative fine up to \$1,000 PER UNCORRECTED VIOLATION in addition to any other penalty provided by law. If this elevator is operating under a complete service maintenance contract, notify your elevator company immediately. IF NO VIOLATIONS ARE INDICATED, DO NOT RETURN THIS FORM.

BCID 33504 Page 1 of 1

J3668026P48362928

ELEVATOR OWNER/MANAGER: I hereby certify that the violations have been corrected.

Signature: _____ Print Name: _____

Title: _____ Date: _____

Sample Elevator Inspection (Approved)



Broward County, Florida

Building Code Services Division

1 North University Drive, Box #302, Plantation, FL 33324-2038

Phone: 954-765-4508 Fax: 954-765-4785

**ELEVATOR INSPECTION REPORT
and
VIOLATIONS TO BE CORRECTED**

Inspection Type:	Routine + Annual	BCID:	33505	License
Result:	Approved with Exceptions	Type:	Hydraulic Passenger	
Inspection Date:	07/11/2017	Floors:	3	Lbs.: 2100
Inspector:	William Redmond CEI #238 (954) 658-1902	Route:	Area 09	
Building Name:	ONE UNIVERSITY DR PARKING GARAGE	Person receiving this report:	John Wallace	
Address:	1 UNIVERSITY DR PLANTATION, FL 33324			
Maintenance Co.:	THYSSENKRUPP ELEVATOR (954) 971-6500	CC #:	3895	

DCF Front (lbs):
DCF Back (lbs):
NL (psi): 200
FL (psi): 310
REL (psi): 350
Gov (E) (fpm):
Gov (M) (fpm):
Slide (in):
BT (ft/lb):
Step/Skirt Index:

Florida Statutes - This device:
Is Exempt: Section 399.15
Alternate power requirements
Is Exempt: Section 553.509
Regional emergency elevator
access/fire key requirements

Violations:

- 404 Lighting, Emergency Lighting, GFCI's 2.14.7 A17.1
One emergency lamp is not illuminating, repair or replace as needed.
- G084 Lighting 106.1e, A17.1, NEC
Pit lamps must be made to illuminate.
- G108 Debris 1206.2, A17.1
Pit must be cleaned.
- H208a Machine Room: Pipes, wiring, & ducts. Foreign equipment.
Remove 55 gallon drum full of old oil removed from pit.

Additional Comments:

When running against stop ring pressure built up to over 600 psi, belts slipping on pump. Mechanic adjusted relief valve within 150% and sealed. Adjust or replace belts as needed. Obtain permit to repair or replace relief valve.

NOTICE TO ELEVATOR OWNER

The violations noted must be corrected and Broward County Building Code Services Division - Elevator Section notified of compliance within 90 DAYS from the date of this inspection. Any elevator owner who fails to comply with this order within 90 days is subject to an administrative fine up to \$1,000 PER UNCORRECTED VIOLATION in addition to any other penalty provided by law. If this elevator is operating under a complete service maintenance contract, notify your elevator company immediately. IF NO VIOLATIONS ARE INDICATED, DO NOT RETURN THIS FORM.

BCID 33505 Page 1 of 1

J3668039P45048160

ELEVATOR OWNER/MANAGER: I hereby certify that the violations have been corrected.

Signature: _____ Print Name: _____

Title: _____ Date: _____

Sample Elevator Inspection (Approved with Exceptions- Pending)



Broward County, Florida

Building Code Services Division

1 North University Drive, Box #302, Plantation, FL 33324-2038

Phone: 954-765-4508 Fax: 954-765-4785

**ELEVATOR INSPECTION REPORT
and
VIOLATIONS TO BE CORRECTED**

Inspection Type: **Routine + Annual**
 Result: **Approved with Exceptions**
 Inspection Date: **07/11/2017**
 Inspector: **William Redmond CEI #238**
 (954) 658-1902

BCID: **33505** License
 Type: **Hydraulic Passenger**
 Floors: **3** Lbs.: **2100**
 Route: **Area 09**

Building Name: **ONE UNIVERSITY DR PARKING GARAGE**
 Address: **1 UNIVERSITY DR
 PLANTATION , FL 33324**

Person receiving this report:
John Wallace

Maintenance Co.: **THYSSENKRUPP ELEVATOR**
 (954) 971-6500

CC #: **3895**

DCF Front (lbs):
 DCF Back (lbs):
 NL (psi): **200**
 FL (psi): **310**
 REL (psi): **350**
 Gov (E) (fpm):
 Gov (M) (fpm):
 Slide (in):
 BT (ft/lb):
 Step/Skirt Index:

Violations:

- 404** Lighting, Emergency Lighting, GFCI's 2.14.7 A17.1
 One emergency lamp is not illuminating, repair or replace as needed.
- G084** Lighting 106.1e, A17.1, NEC
 Pit lamps must be made to illuminate.
- G108** Debris 1206.2, A17.1
 Pit must be cleaned.
- H208a** Machine Room: Pipes, wiring, & ducts. Foreign equipment.
 Remove 55 gallon drum full of old oil removed from pit.

Additional Comments:

When running against stop ring pressure built up to over 600 psi, belts slipping on pump. Mechanic adjusted relief valve within 150% and sealed. Adjust or replace belts as needed. Obtain permit to repair or replace relief valve.

Florida Statutes - This device:

Is Exempt: Section 399.15
 Alternate power requirements

Is Exempt: Section 553.509
 Regional emergency elevator
 access/fire key requirements

NOTICE TO ELEVATOR OWNER

The violations noted must be corrected and Broward County Building Code Services Division - Elevator Section notified of compliance within 90 DAYS from the date of this inspection. Any elevator owner who fails to comply with this order within 90 days is subject to an administrative fine up to \$1,000 PER UNCORRECTED VIOLATION in addition to any other penalty provided by law. If this elevator is operating under a complete service maintenance contract, notify your elevator company immediately. IF NO VIOLATIONS ARE INDICATED, DO NOT RETURN THIS FORM.

BCID 33505 Page 1 of 1

FWAK100901048.001

ELEVATOR OWNER/MANAGER: I hereby certify that the violations have been corrected.

Signature: *John Wallace* Print Name: _____
 Title: *Elevator System Specialist* Date: *3/2/18*

Sample Elevator Inspection (Approved with Exceptions- Received)



Broward County, Florida

TEST SYSTEM (POSTX2)

**ELEVATOR INSPECTION REPORT
and
VIOLATIONS TO BE CORRECTED**

Building Code Services Division

1 North University Drive, Box #302, Plantation, FL 33324-2038

Phone: 954-765-4508 Fax: 954-765-4785

e-mail: elevators@broward.org

Inspection Type: Routine + Annual
 Result: Disapproved
 Inspection Date: 05/01/2018
 Inspector: William Redmond CEI #238
 (954) 658-1902

BCID: 33505 License
 Type: Hydraulic Passenger
 Floors: 3 Lbs.: 2100
 Route: Area 09

Building Name: BROWARD COUNTY GCW PARKING DECK
 Address: 1 UNIVERSITY DR
 PLANTATION, FL 33324
 Person receiving this report:
 Damaris Lugo

Maintenance Co.: EASTERN ELEVATOR SERVICE, INC
 (954) 591-2831
 dlugo@broward.org

DCF Front (lbs):
 DCF Back (lbs):
 NL (psi):
 FL (psi):
 REL (psi):
 Gov (E) (fpm):
 Gov (M) (fpm):
 Slide (in):
 BT (ft/lb):
 Step/Skirt Index:

Violations:

118 Hydraulic Elevator Test Category 1 8.11.3.2 A17.1
 Underline hydraulic piping leaking during testing. Must be
 repaired.

Additional Comments:

A permit to repair underground oil line must be obtained and a
 callback inspection scheduled.

Florida Statutes - This device:**Is Exempt: Section 399.15**Regional emergency elevator
access/fire key requirements**Is Exempt: Section 553.509**

Alternate power requirements

Last Inspection Date Sticker Posted?

No

NOTICE TO ELEVATOR OWNER

The violations noted must be corrected and Broward County Building Code Services Division - Elevator Section notified of compliance within 90 DAYS from the date of this inspection. Any elevator owner who fails to comply with this order within 90 days is subject to an administrative fine up to \$1,000 PER UNCORRECTED VIOLATION in addition to any other penalty provided by law. If this elevator is operating under a complete service maintenance contract, notify your elevator company immediately. IF NO VIOLATIONS ARE INDICATED, DO NOT RETURN THIS FORM.

BCID 33505 Page 1 of 1

J3668039P45756046

ELEVATOR OWNER/MANAGER: I hereby certify that the violations have been corrected.

Signature: _____ Print Name: _____

Title: _____ Date: _____

Sample Elevator Inspection (Disapproved)



Inspection Type: **Alteration**

BCID: 33505 Permit

Result: **Approved**

Type: **Hydraulic Passenger**

Inspection Date: **07/13/2018**

Floors: 3 Lbs.: 2100

Inspector: **William Redmond CEI #238**
(954) 658-1902

Route: **Area 09**

Building Name: **BROWARD COUNTY GCW PARKING DECK**

Person receiving this report:

Address: **1 N UNIVERSITY DR**
PLANTATION, FL 33324

Damaris Lugo

Maintenance Co.: **EASTERN ELEVATOR SERVICE, INC**
(954) 591-2831

dlugo@broward.org
CC #: 0000

DCF Front (lbs): **25**

Violations: NONE

DCF Back (lbs):

Additional Comments:

NL (psi): **200**

Replacement of underground hydraulic oil line approved. See callback report on this date.

FL (psi): **310**

REL (psi): **350**

Gov (E) (fpm):

Gov (M) (fpm):

Slide (in):

BT (ft/lb):

Step/Skirt Index:

Florida Statutes - This device:

Is Exempt: Section 399.15

Regional emergency elevator
access/fire key requirements

Is Exempt: Section 553.509

Alternate power requirements

Last Inspection Date Sticker Posted?

Yes

NOTICE TO ELEVATOR OWNER

The violations noted must be corrected and Broward County Building Code Services Division - Elevator Section notified of compliance within 90 DAYS from the date of this inspection. Any elevator owner who fails to comply with this order within 90 days is subject to an administrative fine up to \$1,000 PER UNCORRECTED VIOLATION in addition to any other penalty provided by law. If this elevator is operating under a complete service maintenance contract, notify your elevator company immediately. IF NO VIOLATIONS ARE INDICATED, DO NOT RETURN THIS FORM.

BCID 33505 Page 1 of 1

J45756064P45756074

ELEVATOR OWNER/MANAGER: I hereby certify that the violations have been corrected.

Signature: _____ Print Name: _____

Title: _____ Date: _____

Sample Elevator Inspection (Alteration)



Building Code Services Division
1 North University Drive, Box #302, Plantation, FL 33324-2038
Phone: 954-765-4508 Fax: 954-765-4785
e-mail: elevators@broward.org

Inspection Type:	Call Back + Annual	BCID:	33505	License
Result:	Approved	Type:	Hydraulic Passenger	
Inspection Date:	07/13/2018	Floors:	3	Lbs.: 2100
Inspector:	William Redmond CEI #238 (954) 658-1902	Route:	Area 09	
Building Name:	BROWARD COUNTY GCW PARKING DECK	Person receiving this report:	Damaris Lugo	
Address:	1 UNIVERSITY DR PLANTATION, FL 33324			
Maintenance Co.:	EASTERN ELEVATOR SERVICE, INC (954) 591-2831	dlugo@broward.org	CC #: 0000	

DCF Front (lbs): 25
 DCF Back (lbs):
 NL (psi): 200
 FL (psi): 310
 REL (psi): 350
 Gov (E) (fpm):
 Gov (M) (fpm):
 Slide (in):
 BT (ft/lb):
 Step/Skirt Index:

Violations: NONE
Additional Comments:
 Violation 118 cited on report dated 05/01/2018 has been corrected.
 See alteration report on this date.

Florida Statutes - This device:

Is Exempt: Section 399.15
 Regional emergency elevator
 access/fire key requirements
Is Exempt: Section 553.509
 Alternate power requirements

Last Inspection Date Sticker Posted?
 Yes

NOTICE TO ELEVATOR OWNER

The violations noted must be corrected and Broward County Building Code Services Division - Elevator Section notified of compliance within 90 DAYS from the date of this inspection. Any elevator owner who fails to comply with this order within 90 days is subject to an administrative fine up to \$1,000 PER UNCORRECTED VIOLATION in addition to any other penalty provided by law. If this elevator is operating under a complete service maintenance contract, notify your elevator company immediately. IF NO VIOLATIONS ARE INDICATED, DO NOT RETURN THIS FORM.

ELEVATOR OWNER/MANAGER: I hereby certify that the violations have been corrected.

Signature: _____ Print Name: _____

Title: _____ Date: _____

Sample Elevator Inspection (Call Back)



Obtaining Inspection Results

- ▶ [Search for Elevator online](#) [BCS - Search for Elevator \(broward.org\)](http://BCS - Search for Elevator (broward.org))

Search for Elevator

Select one of the three search methods to find an Elevator

Search by BCID number
BC ID Number:

OR Search by Phone Access Code
Phone Access Code:

OR Search by Building Name
Building Name:

OR Search by Address
Street Number: e.g. 955
Street Name: e.g. N FEDERAL
City:

Account
Sign In

Permits
Request Inspection
Search for Permit
Search for Address
Request Inspection

Contractor Licenses
Find My Licenses
Search for License
Renew License

Elevators
Search for Elevator
Renew Elevator Certificate



View Elevator

Account

[▶ Sign In](#)

Broward

[▶ BCS Home](#)

[▶ Home](#)

Permits

[▶ Search for Permit](#)

[▶ Search for Address](#)

Contractor Licenses

[▶ Find My Licenses](#)

[▶ Search for License](#)

[▶ Renew License](#)

Elevators

[▶ Search for Elevator](#)

[▶ Renew Elevator Certificate](#)

Certificates Of Use

[▶ Search for C.U.](#)

[▶ Zoning Forms](#)

Enforcement

[▶ Search by Case or Address](#)

[▶ Search by Folio or Parcel](#)

General Information

Status: Licensed
BC ID Number: 33503 License Issue Date: 06/12/2018
Folio Number: License Expiration Date: 08/01/2019
Building Name: BROWARD COUNTY GCW ELEV - 3

Job Location

Address: 1 N UNIVERSITY DR,
PLANTATION , FL 33324

Jurisdiction:
Legal Description:

Owner

Name: BC FACILITIES MAINTENANCE DIVISION

Address: 115 S ANDREWS AVE RM 501
FORT LAUDERDALE, FL 33301

Phone Number: [\(954\) 357-5780](tel:9543575780)
E-mail Address: bleder@broward.org

Elevator Information

Type of Elevator: Hydraulic Passenger
Stories: 4
Landings: 4
Capacity (lbs): 2500
Last Inspection Date: 04/20/2018

Elevator Maintenance Company

Company Name: THYSSENKRUPP ELEVATOR
Company Address: 2801 SW 15 ST
POMPANO BEACH, FL 33069-
Company Phone Number: [\(954\) 971-6500](tel:9549716500)

Fee Information

[Outstanding Fees:](#)

Last Periodic Inspection: 04/20/2018 [\[Click here to view inspection report.\]](#)

Compliance Pending (if any)





Print

BUILDING CODE SERVICES DIVISION | ELEVATOR SAFETY
2307 West Broward Boulevard, Suite 300 • Fort Lauderdale, Florida 33312 • 954-765-4400 Option #4 • Fax: 954-765-4785 • elevators@broward.org

REQUEST FOR CHANGE OF RECORD

BCID# _____

Change of Building Name Change of Building Owner/Company Change of Elevator Service Company

NEW INFORMATION - PLEASE PRINT

Building Name: _____

Building Address: _____

City: _____ State: _____ Zip: _____

Owner or Management Name: _____

Owner or Mgmt Address: _____

City: _____ State: _____ Zip: _____

Phone: _____ Fax: _____ email: _____

Elevator Service Company: _____

Phone: _____ Fax: _____ email: _____

Name of Owner/Manager: _____ Title: _____

Signature of Owner/Manager: _____ Date: _____



Broward County Board of County Commissioners
www.broward.org

Change of Record form



Elevator Owner Responsibilities

- ▶ Safe Operation of the Elevator
- ▶ Proper Maintenance of the Elevator
- ▶ Inspection of the Elevator
- ▶ Correction of code deficiencies of the elevator
- ▶ The elevator owner is responsible to obtain the certificate of operation from Broward County, renew it annually, and post it in plain view inside the elevator.



Elevator Maintenance Company Responsibilities

- ▶ Responsible for ensuring elevator has passed acceptance inspection on new and alteration work.
- ▶ Broward County Code of Ordinances, Sec. 21-8. - Documentation of elevator service:
 - “ Anytime a registered elevator company performs work pursuant to a service maintenance contract, but before leaving the worksite, the company shall provide an ROV (Record of Visit) to the building owner.”
- ▶ All work on an Elevator must be performed by a Certified Elevator Technician.



Variance Process

BROWARD COUNTY FLORIDA
 Resilient Environment Department
BUILDING CODE DIVISION | ELEVATOR PERMITTING
 2307 West Broward Boulevard, Suite #300 • Fort Lauderdale, Florida 33312 • 954-765-4400 • broward.org/building

Petition for Variance
 ASME 17.3 – 1996 Edition; A17.1 – 2007, 2008A, 2009B Edition

Temporary Permanent Date: _____

Elevator Information			
Petitioner Name		Property Name	
Street Address	City	State	Zip
Elevator License / BCID #*		*Please only enter one number per petition	

I, _____ (owner/management company)

do hereby request a variance from the standard 90-day requirement for correction of violations noted on the attached Elevator Inspection, dated _____.

The violations listed on the Elevator Inspection that we cannot complete within 90 days are:
 # _____, # _____, # _____ and # _____.

All remaining violations have been corrected.

Violation Information	
The violations to be corrected are as follows: (check all that apply)	
<input type="checkbox"/> ASME A17.3 Section 2.7.4:	<i>Restricted Opening of Hoistway Doors</i>
<input type="checkbox"/> ASME A17.3 Section 2.7.4, Section 3.11.1:	<i>Car Emergency Signaling Devices</i>
<input type="checkbox"/> ASME A17.3 Section 2.7.4, Section 3.11.3:	<i>Fire Fighter's Service – Phase I and Phase II</i>
<input type="checkbox"/> ASME A17.3 Section 2.7.4, Section 3.4.5:	<i>Car Illumination</i>
<input type="checkbox"/> ASME A17 _____, Section _____:	_____

The reason the 90-day requirement for compliance cannot be met is because:
 (scope of hardship)

The repairs necessary to correct the violations listed above will be completed by:

Elevator Company Name			
Street Address	City	State	Zip
Work Will Begin (date)	Work will be Completed by (date)		

We are a private condominium/owner association and are in the process of complying with the requirement, but due to funding and/or construction delays, the work cannot be completed until the date listed above.

As can be seen from the supporting documentation, we propose to correct the elevator code violations to eliminate risk of injury to riders. We agree to post signage within the elevator that the unit is undergoing modifications and riders will use the conveyance at their own risk.

Copies of all inspections, proposals or signed contracts, letters of intent to comply, plan of corrective action and proof of financial hardship are attached to support this variance request.

All of the following documents must be submitted at the time of application for variance. Please check off the documents as submitted:

- Letter of intent to comply with a plan of corrective action **(required)**
- Signed inspection report(s) showing what has been corrected **(required)**
- Copy of proposal **(required if you do not have a signed contract)**
- Copy of signed contract **(not required if you have a proposal)**
- Copy of construction schedule **(if available)**
- Proof of financial hardship (bank statements, ledgers, etc.) **(required)**

Please Note:
 Cross out all financial (account) and identification numbers on all supporting documents provided
 There is a \$50 administrative fee for each elevator

Signature _____ Date _____

Name _____ Title _____

Email _____ Phone _____



For Change of Record and Inspection Scheduling

- ▶ For Change of Record, please send and email to elevators@broward.org or telephone (954) 765-4400
Option 4
- ▶ Please contact one of the approved registered Third-Party Certified Inspectors to schedule inspections:
- ▶ For Enforcement related matters, please contact ElevatorEnforcement@broward.org



Questions



Useful Forms

- [Approved Third-Party Certified Elevator Inspectors \(CEIs\)](#)
- [Elevator Owners Accident Report - Broward County](#)
- [Petition for Variance](#)
- [Record of Visit \(ROV\): Affidavit](#)
- [Two Stop Elevator Exemption Addendum](#)
- [Two Stop Elevator Exemption Addendum Sample Document FAQs](#)
- [Verified Complaint: ROV](#)



Useful Links

- [Broward County Elevators Section website](#)
- [Elevators FAQ's](#)
- [Broward County Online Permitting \(Search for inspection results\)](#)
- [Renew your Elevator Certificate of Operation Online](#)
- [Florida Bureau of Elevator Safety](#)
- [Elevators Statutes and Rules](#)

