



BROWARD COUNTY BOARD OF RULES AND APPEALS

1 N. University Drive, Suite 3500B
Plantation, FL 33324

Phone: 954-765-4500
Fax: 954-765-4504

broward.org/CodeAppeals

2019 Voting Members

Chair

Mr. Daniel Lavrich, P.E.,
S.I., SECB, F.ASCE, F.SEI
Structural Engineer

Vice-Chair

Mr. Stephen E. Bailey, P.E.,
Electrical Engineer

Mr. Jeffrey Lucas, FM, CFI, CFEI,
Fire Service Professional

Mr. John Famularo,
Roofing Contractor

Mrs. Shalanda Giles Nelson,
General Contractor

Mr. Daniel Rourke,
Master Plumber

Mr. Gregg D'Attile,
Mechanical Contractor

VACANT,

Representative Disabled Community

Mr. Ron Burr,
Swimming Pool Contractor

Mr. John Sims,
Master Electrician

Mr. Dennis A. Ulmer,
Consumer Advocate

Mr. Abbas H. Zackria, CSI,
Architect

Mr. Robert A. Kamm, P.E.,
Mechanical Engineer

Mr. Robert A. Kamm, P.E.,
Mechanical Engineer

Mr. Robert A. Kamm, P.E.,
Mechanical Engineer

Mr. Robert A. Kamm, P.E.,
Mechanical Engineer

Mr. Robert A. Kamm, P.E.,
Mechanical Engineer

Mr. Robert A. Kamm, P.E.,
Mechanical Engineer

2019 Alternate Board Members

Mr. Jeff Falkanger,
Architect

Mr. Steven Feller, P.E.,
Mechanical Engineer

Mr. Alberto Fernandez,
General Contractor

Mr. Robert Taylor,
Fire Service Professional

Mr. Gary Elzweig, P.E.,
Structural Engineer

Mr. David Rice, P.E.,
Electrical Engineer

Mr. James Terry,
Master Plumber

Mr. David Tringo,
Master Electrician

Mr. William Flett,
Roofing Contractor

Mr. William Flett,
Roofing Contractor

Mr. William Flett,
Roofing Contractor

Mr. William Flett,
Roofing Contractor

Mr. William Flett,
Roofing Contractor

Mr. William Flett,
Roofing Contractor

Mr. William Flett,
Roofing Contractor

Mr. William Flett,
Roofing Contractor

Mr. William Flett,
Roofing Contractor

Mr. William Flett,
Roofing Contractor

Mr. William Flett,
Roofing Contractor

Mr. William Flett,
Roofing Contractor

Mr. William Flett,
Roofing Contractor

Mr. William Flett,
Roofing Contractor

Mr. William Flett,
Roofing Contractor

Mr. William Flett,
Roofing Contractor

Mr. William Flett,
Roofing Contractor

To: Members of the Plumbing Technical Advisory Committee
James Terry Daniel Rourke Gregg D'Attile Carl Rasmussen
Albert Korelishn Alan Corriveau

Members of the Electrical Committee

Stephen Bailey Steve Busick Jack Fisher Robert Kamm
Robert Sikorski John Simmons

Staff: Otto Vinas, Chief Plumbing Code Compliance Officer
Ken Castronovo, Chief Electrical Code Compliance Officer
Maria "Pat" Kong, Recording Assistant

Date: November 7, 2019

Subj: Joint Plumbing & Electrical Subcommittee meeting to discuss "Water Heater
replacement"

The Chairman of the Plumbing TAC Committee, Mr. Terry, has called for a joint meeting on Tuesday November 19, 2019 from 10:30AM to 1:00 PM at the West Regional Library Room# 103, 8601 W. Broward Blvd., Plantation, FL 33324.

Agenda

1. Roll Call

Business Items

Item 1: Water Heater replacement requirements

- 1a. Mr. David Rosenof request on behalf of the Broward League of Cities. Pg.3
- 1b. Miami-Dade County permit exemptions on electric water heaters. Pg.5
- 1c. BOAF informal interpretations concerning water heaters. Pg.7
- 1d. FBC, Existing Section 609 Plumbing and Section 607 Electrical. Pg.8
- 1e. Water heater replacement cover forms. Pg.10
- 1f. Rheem electric water heater manual. Pg.13
- 1g.A.O. Smith electric water heater manual. Pg.31
- 1h. Additional information provided by Mr. Castronovo. Pg.50
- 1i. Mr. Gregg D'Attile electronic submittal. Pg.58

General Discussion.

Adjournment.

Sunshine Law Reminder: Advisory Board members cannot communicate with each other on a possible committee or Board topic outside of a public meeting, per State statute.

ITEM 1

Water Heater replacement requirements

Dipietro, James

From: David Rosenof <drosenof@bigdogcsi.com>
Sent: Thursday, May 23, 2019 2:25 PM
To: Dipietro, James
Cc: Daniel J. Stermer (dsterner@westonfl.org); Debra Mink (dkmink@minkandmink.com); jbenning@gfalliance.org
Subject: Board fo Rules and A

Jim, per our conversation I would like to appear in front of BORA on the June 13th meeting at 7:00 PM as a representative of the Broward League of Cities to discuss the following items:

- A uniform permit application for window replacement. I would suggest using Coral Springs as a model
- A uniform permit application for hot water heater replacements.
- A uniform methodology for "Certificates of Completion" when a "Certificate of Occupancy" is not applicable

Please let me know if you need me to bring any backup, otherwise I plan on being there to present the idea and answer any questions from the board.

Thanks

Dave

David J. Rosenof, MBA, CGC, LEED-AP, PMP

President

Big Dog Construction Services, Inc. - CGC 1520372

A Broward County CBE – SBE Contractor

3730 Coconut Creek Parkway #180, Coconut Creek, FL 33066

954-757-8015 – Main Office

866-604-2459 - Fax

www.bigdogcsi.com



#itendshere

#msdpride

4. Recommendation of Mr. David Rosenof on behalf of the Broward County League of Cities to discuss uniform permit applications and certificates of completion on miscellaneous projects throughout Broward County relating to building code permitting submittals

Mr. David Rosenof, representing Broward League of Cities, noted that four years ago he addressed the Board concerning a uniform building permit application for Broward County that was adopted and has been a success. There has been work on standardizing permit applications for roofing and air conditioner change-outs. This evening he is requesting standardization county-wide for hot water heater change-outs and windows. Also, he is suggesting that when a homeowner applies for a building permit, they are advised that a certificate of completion is required. This will provide a more informed way of doing business and eliminate lingering open permits.

Chairman Lavrich suggested the three items be referred to the appropriate committees as follows: window replacements and methodology for certificates of completion to the Structural Committee; and water heater replacements to the Plumbing Committee.

A motion was made by Mr. Ulmer and seconded by Mr. D'Attilio to refer the uniform permit application and certificate of completion requests to the Structural and Plumbing committees as noted above and amended to provide that the committees meeting and bring their recommendations to the Board at their January meeting. The amended motion passed by unanimous vote of 11-0.

During discussion of the above motion, Mr. D'Attilio requested a six-month timeline for all committee work to be completed and presented to the Board.

In response to Mr. Bailey, Mr. Rosenof indicated there are perhaps five permit applications in the county and he would recommend working to combine their best features into one. Mr. Guerasio indicated staff would collect the applicable applications from the municipalities and use this as a starting point.

5. Updating of job description for the title of Administrative Director.
Consideration of changing the pay range. If the pay range is increased, discussion and possible action concerning granting of pay increase

Mr. James DiPietro, Administrative Director, highlighted what has been done in the last few months with respect to every job description, pay range and compensation. The pay range shown in the information provided to the Board was independently developed by Broward County's Human Resources Manager for the Compensation Services Section. The job description itself is twenty years out-of-date.

Mr. Bailey questioned indicating that "Masters degree preferred" in the Minimum Education and Experience Requirements. Mr. DiPietro clarified that the text is essentially the same as the existing job description with updated headings. The

III. Exemptions for Work in Single-family Residences, Duplexes, Townhouses and Condominiur...

The following permit exemptions for single-family residences, duplexes, townhouses and condominiums have been established for unincorporated Miami-Dade County based upon Section 102.2.5 of the Florida Building Code. The total cost in the aggregate of all the below noted work performed by owner-builders or contractors in any 12-month period cannot exceed \$5,000.00. The permit exemptions are as follows:

A. Mechanical

- Replacement of window air conditioning unit.
- Installation of ductless range hoods.

B. Building

- Installation or repair of canvas or cloth covered awnings.
- Installation or repair of rain gutters.
- Enclosure of existing covered patios/balconies/porches with screening.
- Installation of chain-link fences other than those intended to satisfy swimming pool barrier requirements (Requires [Zoning Improvement Permit \(http://www.miamidade.gov/permits/zoning-improvement.asp\)](http://www.miamidade.gov/permits/zoning-improvement.asp)).
- Concrete slabs outside of the building (other than screened patios and pool slabs); items such as, but not limited to, open patios, walkways or garbage containers.

C. Electrical

- Repair work performed by licensed electrical contractors that does not exceed \$500.00 in value of materials and labor.
- The following work is also exempt from permit requirements regardless of the value of materials and labor:
 - Repair or replacement of electrical wall switches and wall outlet devices (receptacles) 20 amps and 120 volts or less.
- Low-voltage electrical systems in single-family residences, duplexes and townhouses (excludes condos).

IV. Exemptions for Minor Repairs on Residential and Commercial Properties

The following permit exemptions for minor repairs have been established for unincorporated Miami-Dade County under Section 105.2.2 of the Florida Building Code:

A. Electrical

- Repair or replacement of electric water heaters 4500 watts or less. If the wattage of the new water heater to be installed is greater than the wattage of the water heater to be replaced, then a permit is required for this work.
- Change out of air conditioning equipment provided it is of the same electrical, cooling/heating and capacity/ampereage.
- Repair or replacement of the following low voltage (under 98 volts) devices:
 - Telephone
 - Television
 - Data Cable
 - Central Vacuum
 - Burglar Alarm
 - Intercom System
- Repair or replacement of electric wiring to pumps less than 1 h.p.
- Repair or replacement of time clocks.

B. Plumbing

- Repair work performed by licensed plumbing contractors that does not exceed \$500.00 in value of materials and labor.
- The following work is also exempt from permit requirements regardless of the value of materials and labor when performed by a licensed plumbing contractor:
 - Repair or replacement of gas appliances, other than water heater, by licensed plumbing contractors.
 - Change out of an above-ground LP tank.
 - Repair irrigation system.
 - Repair domestic water service/lines.
 - Repair to building sewer line, excluding repair or replacement of interceptors/separators, by licensed plumbing contractors.
 - Repair/replacement of faucets.
 - Repair/replacement of water closet/bidet/urinal fixtures only.
 - Repair/replacement of sink/lavatory/drinking fountain fixtures only.
 - Repair/replacement of residential pool equipment other than a pool heater.
 - Repair/replacement of shut-off valve on a domestic water line.
 - Capping of waste line leading to septic tank.
 - Repair/replacement of residential disposal.
 - Repair/replacement of residential dishwasher.
 - Repair/replacement of electric water heater up to 50-gallon capacity by licensed plumbing contractors.

C. Mechanical

- Repair work performed by licensed mechanical contractors that does not exceed \$500 in value of materials and labor.
- The following work is also exempt from permit requirements regardless of the value of materials and labor when performed by a licensed mechanical contractor:
 - Repair of air conditioning duct.
 - Repair or replacement of coil, compressor or refrigerant piping by licensed air conditioning or mechanical contractor.
 - Repair or replacement of non-combustion heating by licensed air conditioning or mechanical contractors.
 - Repair of ventilation fans.

D. Building

- Repair work performed by licensed building contractors that is not structural in nature and does not change the occupancy, does not affect life safety and the value of which does not exceed \$2,000.00 in labor and materials.
- The application, construction or repair of any roof covering performed by a licensed roofing contractor not exceeding \$2,000.00 in value of materials and labor or work not exceeding two roofing squares in extent.

V. Satellite Antennas

Pursuant to federal law, a permit is not required for the installation or repair of satellite antennas that are one meter (approximately 39 inches) or less in diameter which are located on commercial or industrial properties. For residential properties, the installation or repair of satellite antennas attached to primary structures which are one meter (approximately 39 inches) or less in diameter are exempt from permit requirements. Note that permit exemption does not exclude dishes from being safely installed.

Page Last Edited: Thu Dec 27, 2018 1:21:53 PM



**Informal Interpretation Report
Number 6136**



Date 04/14/2009
Report 6136
Edition: 2007
Section 105.1

Question:

Is it the intent of Florida Building Code - Building section 105.1 to require permits for the replacement of gas or electric water heaters? Sections 105.1 and 105.2 are very specific as to required permits and what is exempt from permit. Since "water heater" is not specifically mentioned, should they be exempt?

Answer:

Yes. It is the intent of Florida Building Code - Building section 105.1 to require permits for the replacement of gas and electric water heaters. No, water heater replacements are not exempt from permit requirements.

On 04/21/2009 at 8:03 PM

Commentary:

None.

Notice:

The Building Officials Association of Florida, in cooperation with the Florida Building Commission, the Florida Department of Community Affairs, ICC, and industry and professional experts offer this interpretation of the Florida Building Code in the interest of consistency in their application statewide. This interpretation is informal, non-binding and subject to acceptance and approval by the local building official.

[BS] 606.2 Repairs to damaged buildings. Repairs to damaged buildings shall comply with this section and Section 706, Reroofing.

[BS] 606.2.1 Repairs for less than substantial structural damage. For damage less than *substantial structural damage*, the damaged elements shall be permitted to be restored to their predamage condition.

[BS] 606.2.2 Substantial structural damage to vertical elements of the lateral force-resisting system. A building that has sustained *substantial structural damage* to the vertical elements of its lateral force-resisting system shall be evaluated in accordance with Section 606.2.2.1, and either repaired in accordance with Section 606.2.2.2 or repaired and rehabilitated in accordance with Section 606.2.2.3, depending on the results of the evaluation.

Exceptions:

1. Buildings assigned to Seismic Design Category A, B, or C whose substantial structural damage was not caused by earthquake need not be evaluated or rehabilitated for load combinations that include earthquake effects.
2. One- and two-family dwellings need not be evaluated or rehabilitated for load combinations that include earthquake effects.

[BS] 606.2.2.1 Evaluation. The building shall be evaluated by a registered design professional, and the evaluation findings shall be submitted to the *code official*. The evaluation shall establish whether the damaged building, if repaired to its predamage state, would comply with the provisions of the *Florida Building Code, Building* for load combinations that include wind or earthquake effects, except that the seismic forces shall be the reduced *Florida Building Code, Building*-level seismic forces.

[BS] 606.2.2.2 Extent of repair for compliant buildings. If the evaluation establishes that the building in its predamage condition complies with the provisions of Section 606.2.2.1, then the damaged elements shall be permitted to be restored to their predamage condition.

[BS] 606.2.2.3 Extent of repair for noncompliant buildings. If the evaluation does not establish that the building in its predamage condition complies with the provisions of Section 606.2.2.1, then the building shall be rehabilitated to comply with the provisions of this section. The wind loads for the *repair and rehabilitation* shall be those required by the building code in effect at the time of original construction, unless the damage was caused by wind, in which case the wind loads shall be in accordance with the *Florida Building Code, Building*. The seismic loads for this *rehabilitation* design shall be those required by the building code in effect at the time of original construction, but not less than the reduced *Florida Building Code, Building*-level seismic forces.

[BS] 606.2.3 Substantial structural damage to gravity load-carrying components. Gravity load-carrying components that have sustained *substantial structural damage*

shall be rehabilitated to comply with the applicable provisions for dead and live loads in the *Florida Building Code, Building*. Snow loads shall be considered if the *substantial structural damage* was caused by or related to snow load effects. Undamaged gravity load-carrying components that receive dead, live or snow loads from rehabilitated components shall also be rehabilitated if required to comply with the design loads of the *rehabilitation* design.

[BS] 606.2.3.1 Lateral force-resisting elements. Regardless of the level of damage to gravity elements of the lateral force-resisting system, if substantial structural damage to gravity load-carrying components was caused primarily by wind or seismic effects, then the building shall be evaluated in accordance with Section 606.2.2.1 and, if noncompliant, rehabilitated in accordance with Section 606.2.2.3.

Exceptions:

1. Buildings assigned to Seismic Design Category A, B, or C whose substantial structural damage was not caused by earthquake need not be evaluated or rehabilitated for load combinations that include earthquake effects.
2. One- and two-family dwellings need not be evaluated or rehabilitated for load combinations that include earthquake effects.

[BS] 606.2.4 Flood hazard areas. In *flood hazard* areas, buildings that have sustained *substantial damage* shall be brought into compliance with Section 1612 of the *Florida Building Code, Building*, or Section R322 of the *Florida Building Code, Residential*, as applicable.

SECTION 607 ELECTRICAL

607.1 Material. Existing electrical wiring and equipment undergoing *repair* shall be allowed to be repaired or replaced with like material.

607.1.1 Receptacles. Replacement of electrical receptacles shall comply with the applicable requirements of Section 406.4(D) of NFPA 70.

607.1.2 Plug fuses. Plug fuses of the Edison-base type shall be used for replacements only where there is no evidence of over fusing or tampering per applicable requirements of Section 240.51(B) of NFPA 70.

607.1.3 Nongrounding-type receptacles. For replacement of nongrounding-type receptacles with grounding-type receptacles and for branch circuits that do not have an equipment grounding conductor in the branch circuitry, the grounding conductor of a grounding-type receptacle outlet shall be permitted to be grounded to any accessible point on the grounding electrode system or to any accessible point on the grounding electrode conductor in accordance with Section 250.130(C) of NFPA 70.

607.1.4 Group I-2 receptacles. Non-“hospital grade” receptacles in patient bed locations of Group I-2 shall be replaced with “hospital grade” receptacles, as required by NFPA 99 and Article 517 of NFPA 70.

607.1.5 Grounding of appliances. Frames of electric ranges, wall-mounted ovens, counter-mounted cooking units, clothes dryers and outlet or junction boxes that are part of the existing branch circuit for these appliances shall be permitted to be grounded to the grounded circuit conductor in accordance with Section 250.140 of NFPA 70.

SECTION 608 MECHANICAL

608.1 General. Existing mechanical systems undergoing *repair* shall not make the building less conforming than it was before the *repair* was undertaken.

608.2 Mechanical draft systems for manually fired appliances and fireplaces. A mechanical draft system shall be permitted to be used with manually fired appliances and fireplaces where such a system complies with all of the following requirements:

1. The mechanical draft device shall be listed and installed in accordance with the manufacturer's installation instructions.
2. A device shall be installed that produces visible and audible warning upon failure of the mechanical draft device or loss of electrical power at any time that the mechanical draft device is turned on. This device shall be equipped with a battery backup if it receives power from the building wiring.
3. A smoke detector shall be installed in the room with the appliance or fireplace. This device shall be equipped with a battery backup if it receives power from the building wiring.

SECTION 609 PLUMBING

609.1 Materials. Plumbing materials and supplies shall not be used for repairs that are prohibited in the *Florida Building Code, Plumbing*.

609.2 Water closet replacement. The maximum water consumption flow rates and quantities for all replaced water closets shall be 1.6 gallons (6 L) per flushing cycle.

Exception: Blowout-design water closets [3.5 gallons (13 L) per flushing cycle].



City of Deerfield Beach Building Division
150 NE 2 Avenue, Deerfield Beach, Florida 33441
Telephone: (954) 480-4250 / Fax: (954) 422-5812

WATER HEATER REPLACEMENT
(WATER HEATER STAYING IN SAME LOCATION)

JOB NAME: _____

ADDRESS: _____

"EXISTING UNIT TO BE REPLACED"

ELECTRIC

GAS

Kw: _____
VOLTAGE: _____
WIRE SIZE: _____
BREAKER SIZE: _____
GALLONS: _____

GAS PIPE SIZE: _____
FLUE SIZE & TYPE: _____
BTUHs: _____
GALLONS: _____

"NEW UNIT BEING INSTALLED"

Manufacturer's installation instructions must be provided with permit application.

ELECTRIC

GAS

MAKE: _____
MODEL# _____
Kw: _____
VOLTAGE: _____
WIRE SIZE: _____
BREAKER SIZE: _____
GALLONS: _____

MAKE: _____
MODEL# _____
IGNITER CIRCUIT: NEW EXISTING N/A (circle one)
GAS PIPE SIZE: _____
FLUE SIZE & TYPE: _____
BTUHs: _____
GALLONS: _____

GAS:

Does the combustion air meet the FL Fuel Gas Code; sec. 3047? : YES: _____ NO: _____
If no, submit drawing showing sizes and locations.

ELECTRIC:

a.) Is there any new electrical wiring required for this water heater replacement? : YES: _____ NO: _____

b.) Cord and plug water heater connections may only be used if permitted by the manufacturer's installation instructions as per NEC 422.16(A) and if the water heater is listed by a NRTL for a cord and plug connection.

COMPANY NAME: _____

QUALIFIERS SIGNATURE: _____

CONTRACTORS LIC. #: _____



Town of Hillsboro Beach Building Division
1210 Hillsboro Mile, Hillsboro Beach, FL 33062
Telephone: (954) 427-4011 / Fax: (954) 427-4834

WATER HEATER REPLACEMENT
(WATER HEATER STAYING IN SAME LOCATION)

JOB NAME: _____
ADDRESS: _____

EXISTING UNIT TO BE REPLACED

ELECTRIC

GAS

Kw: _____
VOLTAGE: _____
WIRE SIZE: _____
BREAKER SIZE: _____
GALLONS: _____

GAS PIPE SIZE: _____
FLUE SIZE & TYPE: _____
BTUHs: _____
GALLONS: _____

NEW UNIT BEING INSTALLED

Manufacturer's installation instructions must be provided with permit application.

ELECTRIC

GAS

MAKE: _____
MODEL# _____
Kw: _____
VOLTAGE: _____
WIRE SIZE: _____
BREAKER SIZE: _____
GALLONS: _____

MAKE: _____
MODEL# _____
IGNITER CIRCUIT: NEW EXISTING N/A (circle one)
GAS PIPE SIZE: _____
FLUE SIZE & TYPE: _____
BTUHs: _____
GALLONS: _____

GAS:

Does the combustion air meet the FL Fuel Gas Code; sec. 304? : YES:___ NO:___
If no, submit drawing showing sizes and locations.

ELECTRIC:

a.) Is there any new electrical wiring required for this water heater replacement? : YES:___ NO:___

b.) Cord and plug water heater connections may only be used if permitted by the manufacturer's installation instructions as per NEC 422.16(A) and if the water heater is listed by a NRTL for a cord and plug connection.

COMPANY NAME: _____

QUALIFIERS SIGNATURE: _____

CONTRACTORS LIC. #: _____



ADMINISTRATION DEPARTMENT
BUILDING DIVISION

6591 ORANGE DRIVE • DAVIE, FLORIDA 33314
PHONE: 954.797.1111 • FAX: 954.797.1086 • WWW.DAVIE-FL.GOV

**WATER HEATER REPLACEMENT DATA FORM
2009**

Permit Number: _____

Contractor/ Owner Name: _____

Site Address: _____

Will this be an exact change out? Y___ N___ If not check below.

EXISTING

Gallons _____

Electric total watts

Gas

Heat Pump

Insta-Hot

NEW

Gallons _____

Electric total watts

Gas

Heat Pump

Insta-Hot

I DO SWEAR THAT THE INFORMATION PROVIDED ON THIS FORM IS CORRECT TO MY KNOWLEDGE

QUALIFIER/OWNER'S SIGNATURE: _____

APPROVED BY: _____

THIS FORM MUST BE POSTED WITH PERMIT CARD

Appointments can be made the day of the scheduled inspection – call between the hours of 7:30 am to 8:00 am
Plumbing: 954-797-1141
Electric – 954-797-1160

IMPORTANT SAFETY INFORMATION. READ ALL INSTRUCTIONS BEFORE USING.



⚠ WARNING!

WATER TEMPERATURE ADJUSTMENT

Safety and energy conservation are factors to be considered when selecting the water temperature setting of water heater's thermostat. Water temperatures above 125°F can cause severe burns or death from scalding. Be sure to read and follow the warnings outlined on the label pictured below. This label is also located on the water heater near the thermostat access panel.

DANGER

Water temperature over 125°F can cause severe burns instantly or death from scalds.

Children, disabled and elderly are at highest risk of being scalded.

See instruction manual before setting temperature at water heater.

Feel water before bathing or showering.

Temperature limiting valves are available, see manual.

NOTICE: Mixing valves are available for reducing point of use water temperature by mixing hot and cold water in branch water lines. Contact a licensed plumber or the local plumbing authority for further information.

Time/Temperature Relationship in Scalds

Temperature	Time To Produce a Serious Burn
120°F	More than 5 minutes
125°F	1½ to 2 minutes
130°F	About 30 seconds
135°F	About 10 seconds
140°F	Less than 5 seconds
145°F	Less than 3 seconds
150°F	About 1½ seconds
155°F	About 1 second

Table courtesy of Shriners Burn Institute

The chart shown above may be used as a guide in determining the proper water temperature for your home.

NOTICE: Households with small children, disabled, or elderly persons may require a 120°F or lower thermostat setting to prevent contact with "HOT" water.

The temperature of the water in the heater is regulated by the adjustable surface mounted thermostat(s) located behind the jacket access panel(s). Dual element heaters have two thermostats. To comply with safety regulations the thermostat(s) were set at 120°F before the water heater was shipped from the factory.

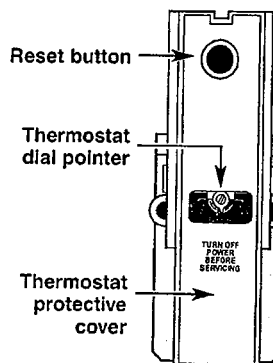

The illustration at the left shows the temperature adjustment dial used for setting the water temperature.

Refer to the Operating Instructions in this manual for detailed instructions in how to adjust the thermostat(s).

⚠ DANGER: Hotter water increase the potential for Hot Water SCALDS.

IMPORTANT SAFETY INFORMATION. READ ALL INSTRUCTIONS BEFORE USING.

Safety Instructions

Installation Instructions

Operating Instructions

Care and Cleaning

Troubleshooting Tips

Customer Service

⚠ WARNING!

For your safety, the information in this manual must be followed to minimize the risk of fire or explosion, electric shock, or to prevent property damage, personal injury, or loss of life.

Be sure to read and understand the entire Use and Care Manual before attempting to install or operate this water heater. It may save you time and cost. Pay particular attention to the Safety Instructions. Failure to follow these warnings could result in serious bodily injury or death. Should you have problems understanding the instructions in this manual, or have any questions, STOP, and get help from a qualified service technician, or the local electric utility.



FOR INSTALLATIONS IN THE STATE OF CALIFORNIA

California Law requires that residential water heaters must be braced, anchored or strapped to resist falling or horizontal displacement due to earthquake motions. For residential water heaters up to 52 gallon capacity, a brochure with generic earthquake bracing instructions can be obtained from: Office of the State Architect, 400 P Street, Sacramento, CA 95814 or you may call 916-324-5315 or ask a water heater dealer.

However, applicable local codes shall govern installation. For residential water heaters of a capacity greater than 52 gallons, consult the local building jurisdiction for acceptable bracing procedures.



SAFETY PRECAUTIONS

Have the installer show you the location of the circuit breaker and how to shut it off if necessary. Turn off the circuit breaker if the water heater has been subjected to overheating, fire, flood, physical damage or if the ECO fails to shut off.

- ⊗ Read this manual entirely before installing or operating the water heater.
- ⊗ Use this appliance only for its intended purpose as described in this Use and Care Manual.
- ⊗ Be sure your appliance is properly installed in accordance with local codes and the provided installation instructions.
- ⊗ Do not attempt to repair or replace any part of your water heater unless it is specifically recommended in this manual. All other servicing should be referred to a qualified technician.



READ AND FOLLOW THIS SAFETY INFORMATION CAREFULLY.

SAVE THESE INSTRUCTIONS

Installing the water heater.

The location chosen for the water heater must take into consideration the following:

Local Installation Regulations

This water heater must be installed in accordance with these instructions, local codes, utility codes, utility company requirements or, in the absence of local codes, the latest edition of the National

Electrical Code. It is available from some local libraries or can be purchased from the National Fire Protection Association, Batterymarch park, Quincy, MA 02269 as booklet ANSI/NFPA 70.

Location

Locate the water heater in a clean dry area as near as practical to the area of greatest heated water demand. Long uninsulated hot water lines can waste energy and water.

Place the water heater in such a manner that the thermostat and element access panels can be removed to permit inspection and servicing such as removal of elements or checking controls.

The water heater and water lines should be protected from freezing temperatures. Do not install the water heater in outdoor, unprotected areas.

CAUTION: The water heater should not be located in an area where leakage of the tank or connections will result in damage to the area adjacent to it or to lower floors of the structure. Where such areas cannot be avoided, it is recommended that a suitable catch pan, adequately drained, be installed under the water heater.

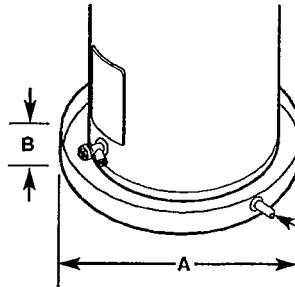

A—Diameter of water heater plus 2" min.
B—Maximum 2"

To open drain, line should be at least 3/4" ID and pitched for proper drainage.

NOTICE: Auxiliary catch pan **MUST** conform to local codes. Catch Pan Kits are available from the store where the water heater was purchased, or any water heater distributor.

Inspect Shipment

Inspect the water heater for possible damage. Check the markings on the rating plate of the water heater to be certain the power supply corresponds to the water heater requirements.

Safety Instructions

Installation Instructions

Operating Instructions

Care and Cleaning

Troubleshooting Tips

Customer Service

Installing the water heater.

Thermal Expansion

Determine if a check valve exists in the inlet water line. It may have been installed in the cold water line as a separate back flow preventer, or it may be part of a pressure reducing valve, water meter or water softener. A check valve located in the cold water inlet line can cause what is referred to as a "closed water system". A cold water inlet line with no check valve or back flow prevention device is referred to as an "open" water system.

As water is heated, it expands in volume and creates an increase in the pressure within the water system. This action is referred to as "thermal expansion". In an "open" water system, expanding water which exceeds the capacity of the water heater flows back into the city main where the pressure is easily dissipated.

A "closed water system", however, prevents the expanding water from flowing back into the main supply line, and the result of "thermal expansion" can create a rapid and dangerous pressure increase in the water heater and system piping. This rapid pressure increase can quickly reach the safety setting of the relief valve, causing it to operate during each heating cycle. Thermal expansion, and the resulting rapid and repeated expansion and contraction of components in the water heater and piping system can cause premature failure of the relief valve, and possibly the heater itself. Replacing the relief valve will not correct the problem!

The suggested method of controlling thermal expansion is to install an expansion tank in the cold water line between the water heater and the check valve (refer to the illustration below). The expansion tank is designed with an air cushion built in that compresses as the system pressure increases, thereby relieving the over pressure condition and eliminating the repeated operation of the relief valve. Other methods of controlling thermal expansion are also available. Contact your installing contractor, water supplier or plumbing inspector for additional information regarding this subject.

Water Supply Connections

NOTICE: Do not apply heat to the HOT or COLD water connections. If sweat connections are used, sweat tubing to adapter before fitting adapter to the water connections on heater. Any heat applied to the water supply fittings will permanently damage the dip tube and/or heat traps.

Refer to the illustration below for suggested typical installation. The installation of unions or flexible copper connectors is recommended on the hot and cold water connections so that the water heater may be easily disconnected for servicing if necessary. The HOT and COLD water connections are clearly marked and are 3/4" NPT on all models. Install a shut-off valve in the cold water line near the water heater.

Typical Installation

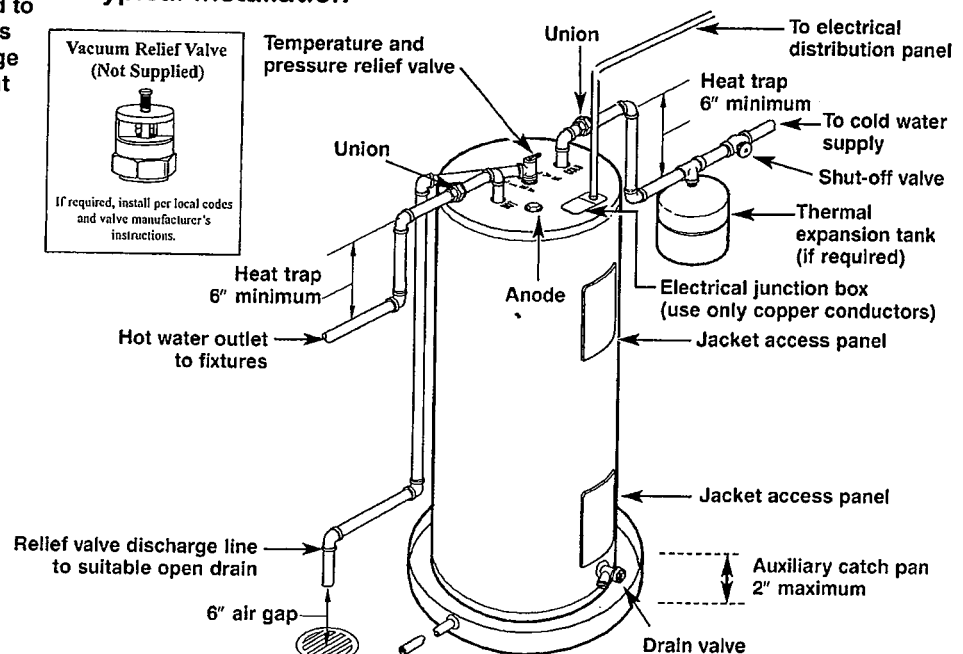

A new combination temperature and pressure relief valve, complying with the Standard for Relief Valves and Automatic Gas Shut-Off Devices for Hot Water Supply Systems, ANSI Z21.22, is supplied and must remain installed in the opening provided and marked for the purpose on the water heater. No valve of any type should be installed between the relief valve and the tank. Local codes shall govern the installation of relief valves.

Relief Valve

▲ WARNING: The pressure rating of the relief valve must not exceed 150 PSI, the maximum working pressure of the water heater as marked on the rating plate.

The BTUH rating of the relief valve must not be less than the input rating of the water heater as indicated on the rating label located on the front of the heater (1 watt=3.412 BTUH).

Connect the outlet of the relief valve to a suitable open drain so that the discharge water cannot contact live electrical parts or persons and to eliminate potential water damage.

Piping used should be of a type approved for hot water distribution. The discharge line must be no smaller than the outlet of the valve and must pitch downward from the valve to allow complete drainage (by gravity) of the relief valve and discharge line. The end of the discharge line should not be threaded or concealed and should be protected from freezing. No valve of any type, restriction or reducer coupling should be installed in the discharge line.

To Fill the Water Heater

▲ WARNING: The tank must be full of water before heater is turned on. The water heater warranty does not cover damage or failure resulting from operation with an empty or partially empty tank. (Refer to the Certificate of Limited Warranty for complete terms and conditions.)

Make certain the drain valve is completely closed.

Open the shut-off valve in the cold water supply line.

Open each hot water faucet slowly to allow the air to vent from the water heater and piping.

A steady flow of water from the hot water faucet(s) indicates a full water heater.

Condensation

Condensation can form on the tank when it is first filled with water. Condensation might also occur with a heavy water draw and very cold inlet water temperature.

This condition is not unusual, and will disappear after the water becomes heated. If, however, the condensation continues, examine the piping and fittings for possible leaks.

Additional information on this subject may be found at www.rheem.com under "Library". Scroll down to the Technical Service Bulletins 1300 Series Section and choose Bulletin #1303.

Installing the water heater.

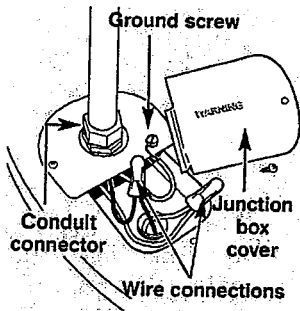

Water heater junction box.

CAUTION: The presence of water in the piping and water heater does not provide sufficient conduction for a ground. Non-metallic piping, dielectric unions, flexible connectors etc. can cause the water heater to be electrically isolated.

Electrical Connections

A separate branch circuit with copper conductors, overcurrent protective device and suitable disconnecting means must be provided by a qualified electrician.

All wiring must conform to local codes or latest edition of National Electrical Code ANSI/NFPA 70.

The water heater is completely wired to the junction box inside jacket at the top front of the water heater. An opening for 1/2" or 3/4" electrical fitting is provided for field wiring connections.

The voltage requirements and wattage load for the water heater are specified on the rating plate on the front of the water heater.

The branch circuit wiring should include either:

- ① Metallic conduit or metallic sheathed cable approved for use as a grounding conductor and installed with fittings approved for the purpose.
- ② Non-metallic sheathed cable, metallic conduit or metallic sheathed cable not approved for use as a ground conductor shall include a separate conductor for grounding. It should be attached to the ground terminals of the water heater and the electrical distribution box.

NOTICE: This guide recommends minimum branch circuit sizing and wire size based on National Electric Code. Refer to wiring diagrams in this manual for field wiring connections.

Branch Circuit Sizing and Wire Size Guide

Total Water Heater Wattage	Recommended Over Current Protection (fuse or circuit breaker amperage rating)				Copper Wire Size AWG Based on N.E.C. Table 310-16 (75°C)			
	208V	240V	277V	480V	208V	240V	277V	480V
3,000	20	20	15	15	12	12	14	14
4,000	25	25	20	15	10	10	12	14
4,500	30	25	25	15	10	10	10	14
5,000	30	30	25	15	10	10	10	14
5,500	35	30	25	15	8	10	10	14
6,000	40	35	30	20	8	8	10	12
8,000	50	45	40	25	8	8	8	10
9,000	-	50	45	25	-	8	8	10
10,000	-	-	50	30	-	-	8	10
11,000	-	-	50	30	-	-	8	10
12,000	-	-	-	35	-	-	-	8

Insulation Blankets

⚠ WARNING: If local codes require external application of insulation blanket kits the manufacturer's instructions included with the kit must be carefully followed.

Insulation blankets, available to the general public, for external use on electric water heaters are not necessary. The purpose of an insulation blanket is to reduce the standby heat loss encountered with storage tank heaters. This water heater meets or exceeds the National Appliance Energy Conservation Act standards with respect to insulation and standby loss requirements making an insulation blanket unnecessary.

The manufacturer's warranty does not cover any damage or defect caused by installation, attachment or use of any type of energy saving or other unapproved devices (other than those authorized by the manufacturer) into, onto or in conjunction with the water heater. The use of unauthorized energy saving devices may shorten the life of the water heater and may endanger life and property.

The manufacturer disclaims any responsibility for such loss or injury resulting from the use of such unauthorized devices.

⚠ CAUTION: If local codes require the application of an external insulation blanket to this water heater, pay careful attention to the following so as not to restrict the proper function and operation of the water heater:

- ❶ Do not cover the operating or warning labels attached to the water heater or attempt to relocate them on the exterior of insulation blanket.
- ❷ Do not apply insulation to the top of the water heater. This could interfere with the safe operation of the electrical junction box.
- ❸ Do not cover the jacket access panel(s) to the thermostat(s) and heating element(s), or pressure and temperature relief valve.
- ❹ Inspect the insulation blanket frequently.

Hot and Cold Pipe Insulation Installation

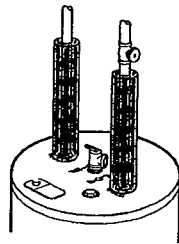

Typical vertical piping arrangement

For increased energy efficiency, some water heaters have been supplied with two 24" sections of pipe insulation.

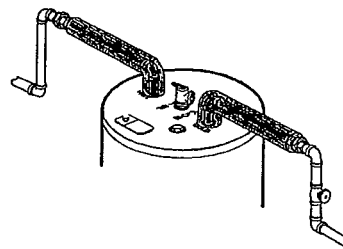

Typical horizontal piping arrangement

Please install the insulation, according to the illustrations above, that best meets your requirements.

Installing the water heater.

Relief Valve Insulation Installation

⚠ CAUTION: Ensure the T&P Valve opening is not obstructed by the insulation.

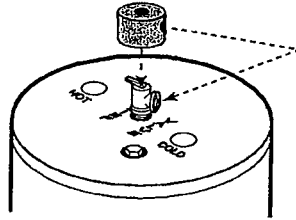

Typical top connection arrangement

For increased energy efficiency, some water heaters have been supplied with a 2-3/8" section of pipe insulation.

Please install the insulation, according to the illustrations above, that best meets your requirements.

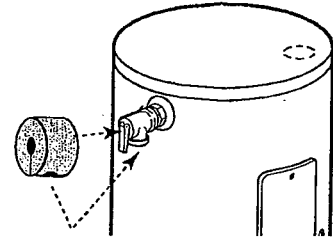

Typical side connection arrangement

Slip the insulation cover over the T&P Valve through the center hole and align the hole in the side with the opening of the T&P Valve.

Heat Trap

For increased energy efficiency, some water heaters have been supplied with factory installed heat traps in the hot outlet line and cold water inlet line.

NOTICE: Do not apply heat to the hot or cold water connections. If sweat connections are used, sweat tubing to adapter before fitting adapter to the water connections on heater. Any heat applied to the water supply fittings will permanently damage the dip tube and/or heat traps.

Installation checklist.

A Water Heater Location

- Close to area of heated water demand.
 - Indoors and protected from freezing temperatures.
 - Area free of flammable vapors.
 - Sufficient fresh air supply for proper operation of water heater.
 - Provisions made to protect area from water damage.
 - Sufficient room to service heater.
-

B Water Supply

- Water heater completely filled with water.
 - Air purged from water heater and piping.
 - Water connections tight and free of leaks.
-

C Relief Valve

- Temperature and Pressure Relief Valve properly installed and discharge line run to open drain.
 - Discharge line protected from freezing.
-

D Wiring

- Power supply voltage agrees with water heater rating plate.
- Branch circuit wire and fusing or circuit breaker of proper size.
- Electrical connections tight and unit properly grounded.

Safety Instructions

Installation Instructions

Operating Instructions

Care and Cleaning

Troubleshooting Tips

Customer Service

Operating the water heater.

⚠ CAUTION: Hydrogen gas can be produced in a hot water system served by this water heater that has not been used for a long period of time (generally two weeks or more). **HYDROGEN GAS IS EXTREMELY FLAMMABLE!!** To dissipate such gas and to reduce risk of injury, it is recommended that the hot water faucet be opened for several minutes at the kitchen sink before using any electrical appliance connected to the hot water system. If hydrogen is present, there will be an unusual sound such as air escaping through the pipe as the water begins to flow. Do not smoke or use an open flame near the faucet at the time it is open.

Safety Precautions

- A** Do not turn off power to water heater if it has been subjected to over heating, fire, flood, physical damage.
- B** Do Not turn on water heater unless it is filled with water.
- C** Do Not turn on water heater if cold water supply shut-off valve is closed.
- D** If there is any difficulty in understanding or following the Operating Instructions or the Care and Cleaning section, it is recommended that a qualified person or serviceman perform the work.

Safety Controls

The water heater is equipped with a combination thermostat and temperature limiting control (ECO) that is located above the heating element in contact with the tank surface. If for any reason the water temperature becomes excessively high, the temperature limiting control (ECO) breaks the power circuit to the heating element. Once the control opens, it must be reset manually.

⚠ CAUTION: The cause of the high temperature condition must be investigated by qualified service technician and corrective action must be taken before placing the water heater in service again.

To reset the temperature limiting control:

- 1** Turn off the power to the water heater.
- 2** Remove the jacket access panel(s) and insulation.
The thermostat protective cover should not be removed.
- 3** Press the red RESET button.
- 4** Replace the insulation and jacket access panel(s) before turning on the power to the water heater.

⚠ WARNING: If the water heater has been subjected to flood, fire, or physical damage, turn off power and water to the water heater.

Do not operate the water heater again until it has been thoroughly checked by qualified service personnel.

Water Temperature Setting

⚠ DANGER: There is a hot water scald potential if the thermostat is set too high. Households with small children, disabled, or elderly persons may require a 120°F or lower thermostat setting to prevent contact with HOT water.

The temperature of the water in the water heater can be regulated by setting the temperature dial of the adjustable surface mounted thermostat(s) located behind the jacket access panel(s).

Dual element heaters have two thermostats.

Safety and energy conservation are factors to be considered when selecting the water temperature setting of the water heater's thermostat(s). The lower the temperature setting, the greater the savings in energy and operating costs.

To comply with safety regulations the thermostat(s) are factory set at 120°F or less where local codes require. This is the recommended starting point.

Water temperatures above 125°F can cause severe burns or death from scalding. Be sure to read and follow the warnings outlined in this manual and on the label on the water heater. This label is located on the water heater near the thermostat access panel.

Mixing valves for reducing point of use water temperature by mixing hot and cold water in branch water lines are available. Contact a licensed plumber or the local plumbing authority for further information.

The chart below may be used as a guide in determining the proper water temperature for your home.

Time/Temperature Relationship in Scalds

Temperature	Time To Produce a Serious Burn
120°F	More than 5 minutes
125°F	1½ to 2 minutes
130°F	About 30 seconds
135°F	About 10 seconds
140°F	Less than 5 seconds
145°F	Less than 3 seconds
150°F	About 1½ seconds
155°F	About 1 second

Table courtesy of Shriners Burn Institute

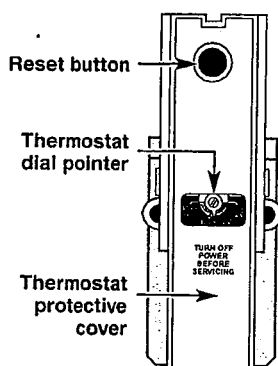

Type 59T thermostat and protective cover.

If adjustment is necessary...

- 1 Turn off the power to the water heater.
- 2 Remove the jacket access panel(s) and insulation exposing the thermostat(s).
The thermostat protective cover(s) should not be removed.
- 3 Using a small screwdriver, set the thermostat(s) dial pointer(s) to the desired temperature.
- 4 Replace the insulation and jacket access panel(s). Turn on the power to the water heater.

Care and cleaning of the water heater.

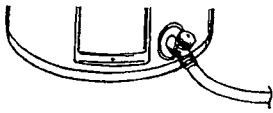

Draining the Water Heater

▲ CAUTION: Shut off power to the water heater before draining water.

▲ DANGER: Before manually operating the relief valve, make certain no one will be exposed to the hot water released by the valve. The water drained from the tank may be hot enough to present a scald hazard and should be directed to a suitable drain to prevent injury or damage.

In order to drain the water heater, turn off the cold water supply. Open a hot water faucet or lift the handle on the relief valve to admit air to the tank.

Attach a garden hose to the drain valve on the water heater and direct the stream of water to a drain. Open the valve.

NOTICE: Refer to the Hydrogen Gas Caution in the Operating Instructions.

Vacation and Extended Shut-Down

If the water heater is to remain idle for an extended period of time, the power and water to the appliance should be turned off to conserve energy and prevent a build-up of dangerous hydrogen gas.

The water heater and piping should be drained if they might be subjected to freezing temperatures.

After a long shut-down period, the water heater's operation and controls should be checked by qualified service personnel. Make certain the water heater is completely filled again before placing it in operation.

▲ DANGER: Before manually operating the relief valve, make certain no one will be exposed to the danger of coming in contact with the hot water released by the valve. The water may be hot enough to create a scald hazard. The water should be released into a suitable drain to prevent injury or property damage.

NOTICE: If the temperature and pressure relief valve on the hot water heater discharges periodically, this may be due to thermal expansion in a closed water system. Contact the water supplier or your plumbing contractor on how to correct this. Do not plug the relief valve outlet.

Routine Preventative Maintenance

Properly maintained, your water heater will provide years of dependable trouble-free service.

It is suggested that a routine preventive maintenance program be established and followed by the user.

It is further recommended that a periodic inspection of the operating controls, heating element and wiring should be made by service personnel qualified in electric appliance repair.

Most electrical appliances, even when new, make some sound when in operation. If the hissing or singing sound level increases excessively, the electric heating element may require cleaning. Contact a qualified installer or plumbing contract to inspect.

At least once a year, lift and release the lever handle on the temperature pressure relief valve, located near the top of the water heater, to make certain the valve operates freely. Allow several gallons to flush through the discharge line to an open drain.

A water heater's tank can act as a setting basin for solids suspended in the water. It is therefore not uncommon for hard water deposits to accumulate in the bottom of the tank. It is suggested that a few quarts of water be drained from the water heater's tank every month to clean the tank of these deposits.

Rapid closing of faucets or solenoid valves in automatic water using appliances can cause a banging noise heard in a water pipe. Strategically located risers in the water pipe system or water hammer arresting devices can be used to minimize the problem.

The anode rod should be removed from the water heater's tank annually for inspection and replaced when more than 6" of core wire is exposed at either end of the rod.

Make sure the cold water supply is turned off before removing anode rod.

NOTICE: Do not remove the anode rod from the water heater's tank, except for inspection and/or replacement, as operation with the anode rod removed will shorten the life of the glass lined tank and will exclude warranty coverage.

Before You Call For Service...



Troubleshooting Tips
 Save time and money! Review the chart on this page first and you may not need to call for service.

Problem	Possible Causes	What To Do
Rumbling noise	Water conditions in your home caused a build up of scale or mineral deposits on the heating elements.	⊗ Remove and clean the heating elements.
Relief valve producing popping noise or draining	Pressure build up caused by thermal expansion in a closed system.	⊗ This is an unacceptable condition and must be corrected. Contact the water supplier or plumbing contractor on how to correct this. Do not plug the relief valve outlet.
Rattling noise during periods of water usage	Internal heat trap fittings in operation.	⊗ This is normal for heat trap fittings when in operation and does not indicate a need for service.
Not enough or no hot water	Water usage may have exceeded the capacity of the water heater.	⊗ Wait for the water heater to recover after an abnormal demand.
	A fuse is blown or a circuit breaker tripped.	⊗ Replace fuse or reset circuit breaker.
	Electric supply may be off.	⊗ Make sure electric supply to water heater and disconnect switch, if used, are in the ON position.
	The thermostat may be set too low.	⊗ See the Temperature regulation of the water heater section of this manual.
	Leaking or open hot water faucets.	⊗ Make sure all faucets are closed.
	Electric service to your home may be interrupted.	⊗ Contact the local electric utility.
	Improper wiring.	⊗ See the Installing the water heater section of this manual.
	Manual reset limit (ECO).	⊗ See the Temperature regulation of the water heater section of this manual.
Water is too hot	Cold water inlet temperature may be colder during the winter months.	⊗ This is normal. The colder inlet water takes longer to heat.
	The thermostat is set too high.	⊗ See the Temperature regulation of the water heater section of this manual.

⚠ CAUTION: For your safety DO NOT attempt repair of electrical wiring, thermostats, heating elements or other safety devices. Refer repairs to qualified service personnel.

Safety Instructions

Installation Instructions

Operating Instructions

Care and Cleaning

Troubleshooting Tips

Customer Service

Replacement Parts.

For 20–120 gallon models with single and double elements.

Instructions For Placing a Parts Order

To place orders using a Visa/MasterCard call 800-431-1549.

All parts orders should include:

- 1 The model and serial number of the water heater from the rating plate.
- 2 Specify voltage and wattage as marked on the rating plate.

- 3 Part description (as noted below) and number of parts desired.

CAUTION: For your safety DO NOT attempt repair of electrical wiring, thermostat(s), heating elements or other operating controls. Refer repairs to qualified service personnel.

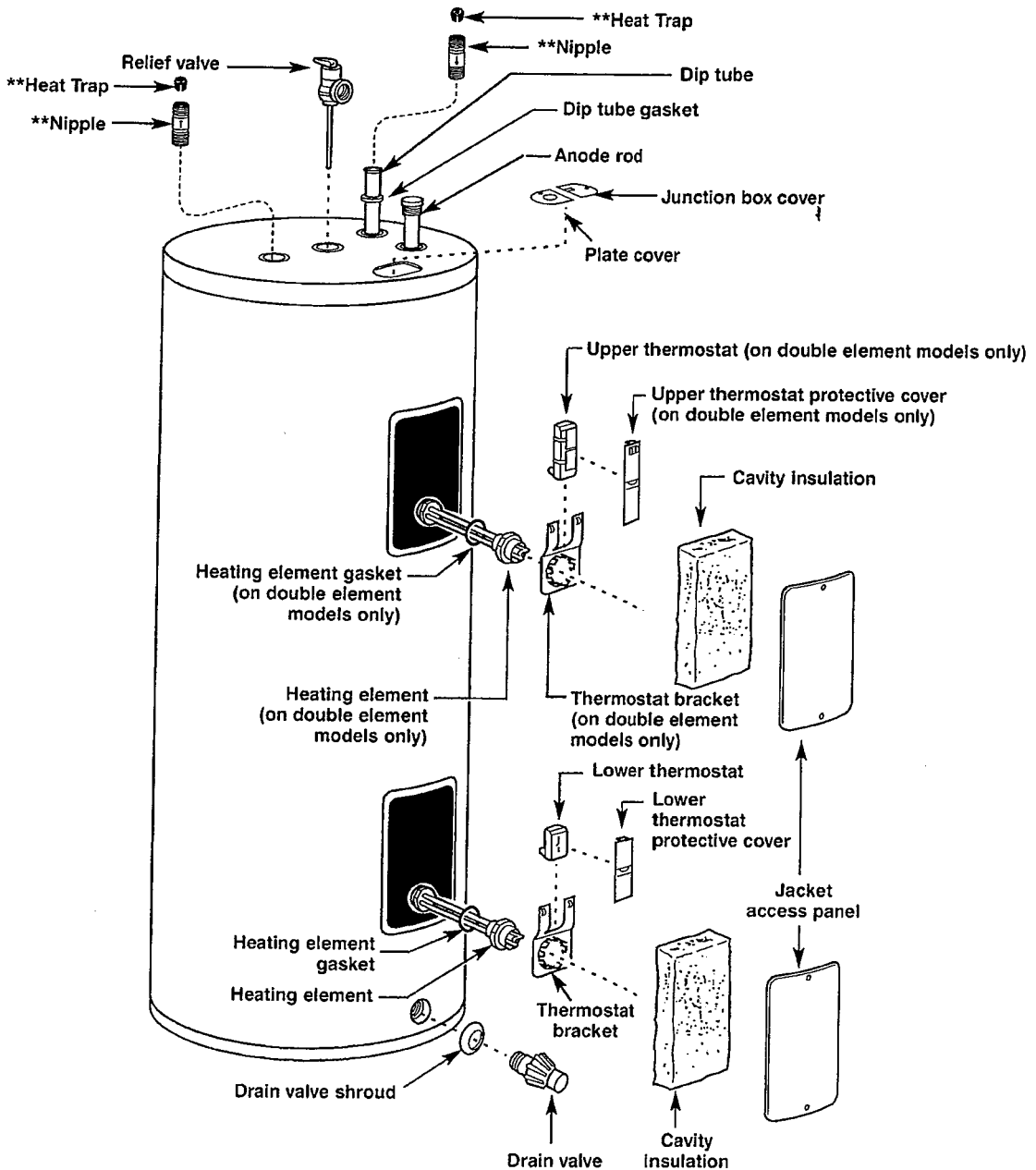

16 **Not supplied on all models

Cavity Insert Instructions

The following instructions are intended for qualified service personnel **ONLY**, and should only be done when necessary.

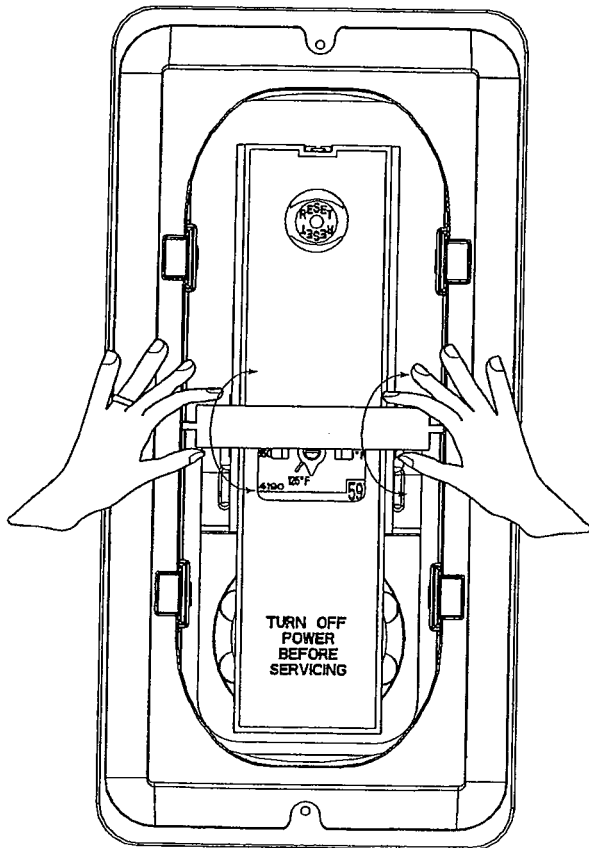

In order to replace the thermostat or heating element, remove the cavity insert crossbar by following the instructions below:

- 1 Turn off the power to the water heater.
- 2 Remove the jacket access panel(s) and insulation.
- 3 Rotate the crossbar up and down until it breaks away from the remainder of the cavity insert. (See illustration to the left)

Discard the crossbar. It cannot and need not be replaced.

- 4 Replace the thermostat and/or element as necessary.
- 5 Replace the insulation and jacket access panel(s) before turning on the power to the water heater.

NOTICE: The cavity insert crossbar is necessary for the manufacturing process only. The removal of the crossbar will not interfere with the operation of the water heater.

Safety Instructions

Installation Instructions

Operating Instructions

Care and Cleaning

Troubleshooting Tips

Customer Service

Wiring diagrams.

Wiring Diagrams for Type-59T Therm-o-disc Thermostats

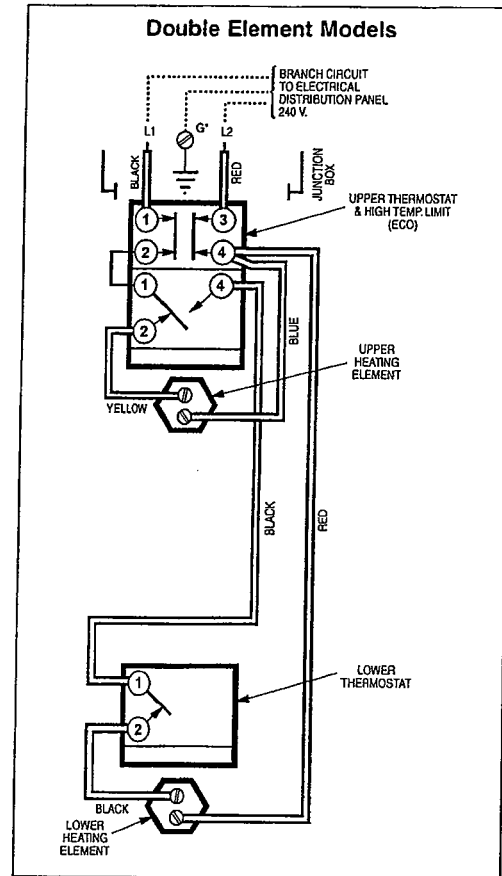
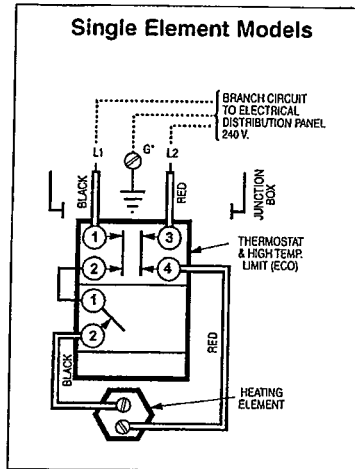

Cut here

Cut here

Please place in envelope and mail to:

Rheem Manufacturing Company
Warranty Registration Department
P.O. Box 34070
Louisville, KY 40232-4070

Consumer Product Ownership Registration

Follow these three steps to protect your new appliance investment:

1

Complete and mail this Consumer Product Ownership Registration today.

2

After mailing the registration below, store this document in a safe place. It contains information you will need should you require service.

3

Read your Owner's Manual carefully. It will help you operate your new appliance properly.

Model Number Serial Number

If you require service, call 800-431-1549.

 Cut here

Consumer Product Ownership Registration



Water Heater

Model Number

Serial Number

Mr. Ms. Mrs. Miss

First Name _____

Last Name _____

Street Address _____

Apt. # _____

City _____

State _____ Zip Code _____

Date Placed in Use: Month _____ Day _____ Year _____

Phone Number _____-_____-_____

NOTICE: Failure to complete and return this card does not diminish your limited warranty rights.

A.O. Smith Water Heaters

Instruction Manual

RESIDENTIAL ELECTRIC WATER HEATERS

FOR POTABLE WATER
HEATING ONLY

NOT SUITABLE FOR
SPACE HEATING

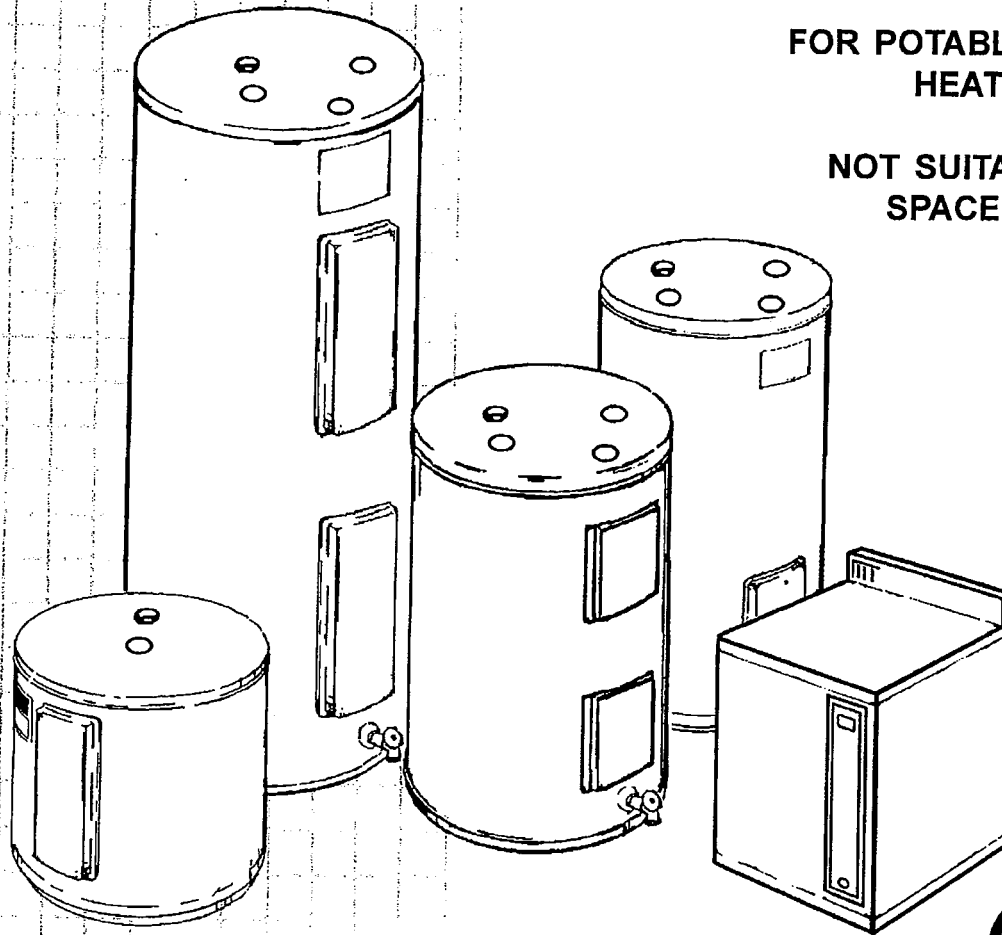

GAMA certification applies to all residential electric water heaters with capacities of 20 to 120 gallons. Input rating of 12 Kw or less.

	⚠ WARNING
	<p>Read and understand instruction manual and safety messages before installing, operating or servicing this water heater.</p> <p>Failure to follow instructions and safety messages could result in death or serious injury.</p> <p>Instruction manual must remain with water heater.</p>

ALL TECHNICAL AND WARRANTY QUESTIONS: SHOULD BE DIRECTED TO THE LOCAL DEALER FROM WHOM THE WATER HEATER WAS PURCHASED. IF YOU ARE UNSUCCESSFUL, PLEASE WRITE TO THE COMPANY LISTED ON THE RATING PLATE ON THE WATER HEATER.





KEEP THIS MANUAL IN THE POCKET ON HEATER FOR FUTURE REFERENCE
WHEN EVER MAINTENANCE ADJUSTMENT OR SERVICE IS REQUIRED.

SAFE INSTALLATION, USE AND SERVICE

Your safety and the safety of others is extremely important in the installation, use and servicing of this water heater.

Many safety-related messages and instructions have been provided in this manual and on your own water heater to warn you and others of a potential injury hazard. Read and obey all safety messages and instructions throughout this manual. It is very important that the meaning of each safety message is understood by you and others who install, use or service this water heater.

	<p>This is the safety alert symbol. It is used to alert you to potential personal injury hazards. Obey all safety messages that follow this symbol to avoid possible injury or death.</p>
---	---

	<p>DANGER indicates an imminently hazardous situation which, if not avoided, could result in death or injury.</p>
	<p>WARNING indicates a potentially hazardous situation which, if not avoided, could result in death or injury.</p>
	<p>CAUTION indicates a potentially hazardous situation which, if not avoided, may result in minor or moderate injury.</p>
	<p>CAUTION used without the safety alert symbol indicates a potentially hazardous situation which, if not avoided, could result in property damage.</p>

All safety messages will generally tell you about the type of hazard, what can happen if you do not follow the safety message and how to avoid the risk of injury.

IMPORTANT DEFINITIONS

- Qualified Installer:** A qualified installer must have ability equivalent to a licensed tradesman in the fields of plumbing, and electrical installation of these appliances. This would include a thorough understanding of the requirements of the National Electrical Code and applicable local electrical and plumbing codes (and tools necessary to confirm proper installation and operation of the water heater) as they relate to the installation of electric water heaters. The qualified installer must have a thorough understanding of the water heater Instruction Manual.
- Service Agency:** A service agency also must have ability equivalent to a licensed tradesman in the fields of plumbing, and electrical installation of these appliances. This would include a thorough understanding of the requirements of the National Electrical Code and applicable local electrical and plumbing codes (and tools necessary to confirm proper installation and operation of the water heater) as they relate to the installation of electric water heaters. The service agency must have a thorough understanding of the water heater Instruction Manual.

GENERAL SAFETY



⚠ WARNING

Read and understand instruction manual and safety messages before installing, operating or servicing this water heater.

Failure to follow instructions and safety messages could result in death or serious injury.

Instruction manual must remain with water heater.

CAUTION

Improper installation and use may result in property damage.

- Do not operate water heater if flood damaged.
- Inspect and replace anode.
- Install in location with drainage.
- Fill tank with water before operation.
- Be alert for thermal expansion.

Refer to instruction manual for installation and service.

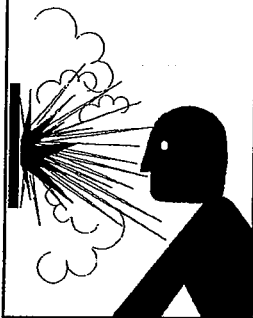

⚠ WARNING

Explosion Hazard

- Overheated water can cause watertank explosion.
- Properly sized temperature and pressure relief valve must be installed in opening provided.

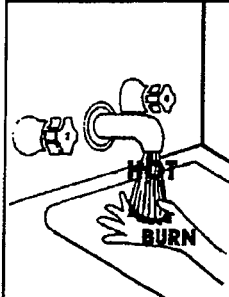

⚠ DANGER

Water temperature over 125°F (52°C) can cause severe burns instantly resulting in severe injury or death.

Children, the elderly, and the physically or mentally disabled are at highest risk for scald injury.

Feel water before bathing or showering.

Temperature limiting valves are available.

Read instruction manual for safe temperature setting.



⚠ WARNING

- Before removing any access panels or servicing the water heater, make sure the electrical supply to the water heater is turned "OFF".
- Failure to do this could result in death, serious bodily injury, or property damage.

TABLE OF CONTENTS

SAFE INSTALLATION, USE AND SERVICE	2	Temperature Adjustment	11
GENERAL SAFETY	3	FOR YOUR INFORMATION	12
TABLE OF CONTENTS	3	Thermal Expansion	12
INTRODUCTION	4	Strange Sounds	12
Preparing for the New Installation	4	Operational Conditions	12
NOTES	4	Smelly Water	12
TYPICAL INSTALLATION	5	"Air" in Hot Water Faucets	12
WIRING DIAGRAMS	6	High Water Temperature Shut Off System	12
MIXING VALVE USAGE	7	PERIODIC MAINTENANCE	12
LOCATING THE NEW WATER HEATER	8	Anode Rod Inspection	12-13
Facts to Consider About Location	8	Temperature-Pressure Relief Valve Operation	13
Insulation Blankets	8	Draining	13
INSTALLING THE NEW WATER HEATER	8	Drain Valve Washer Replacement	13
Water Piping	8-9	Service	13
Temperature-Pressure Relief Valve	9-10	LEAKAGE CHECKPOINTS	14
Filling the Water Heater	10	REPAIR PARTS LIST	15
T&P Valve and Pipe Insulation (Selected Models)	10	TROUBLESHOOTING	16
TEMPERATURE REGULATION	11	WARRANTY	17-18

INTRODUCTION

Thank You for purchasing this water heater. Properly installed and maintained, it should give you years of trouble free service.

Abbreviations Found In This Instruction Manual:

- ANSI - American National Standards Institute
- ASME - American Society of Mechanical Engineers
- GAMA - Gas Appliance Manufacturer's Association
- NEC - National Electric Code
- NFPA - National Fire Protection Association
- UL - Underwriters Laboratory

PREPARING FOR THE INSTALLATION

1. Read the "General Safety" section of this manual first and then the entire manual carefully. If you don't follow the safety rules, the water heater will not operate properly. It could cause DEATH, SERIOUS BODILY INJURY AND/OR PROPERTY DAMAGE.

This manual contains instructions for the installation, operation, and maintenance of the electric water heater. It also contains warnings throughout the manual that you must read and be aware of. All warnings and all instructions are essential to the proper operation of the water heater and your safety. Since we cannot put everything on the first few pages, **READ THE ENTIRE MANUAL BEFORE ATTEMPTING TO INSTALL OR OPERATE THE WATER HEATER.**

2. The installation must conform with these instructions and the local code authority having jurisdiction and the requirements of the power company. In the absence of code requirements follow NFPA-70 (latest edition). The National Electric Code which may be ordered from: National Fire Protection Association, 1 Batterymarch Park, Quincy, MA 02269.
3. If after reading this manual you have any questions or do not understand any portion of the instructions, call the local utility or the manufacturer whose name appears on the rating plate.
4. Carefully plan the place where you are going to put the water heater. **INSTALLATION OR SERVICE OF THIS WATER HEATER REQUIRES ABILITY EQUIVALENT TO THAT OF A LICENSED TRADESMAN IN THE FIELD INVOLVED. PLUMBING AND ELECTRICAL WORK ARE REQUIRED.**

Examine the location to ensure the water heater complies with the "Facts to Consider About the Location" section in this manual.

5. For California installation this water heater must be braced, anchored, or strapped to avoid falling or moving during an earthquake. See instructions for correct installation procedures. Instructions may be obtained from California Office of the State Architect, 400 P Street, Sacramento, CA 95814.
6. Massachusetts Code requires this water heater to be installed in accordance with Massachusetts 248-CMR 2.00: State Plumbing Code and 248-CMR 5.00.

NOTES

TYPICAL INSTALLATION

LOWBOYS

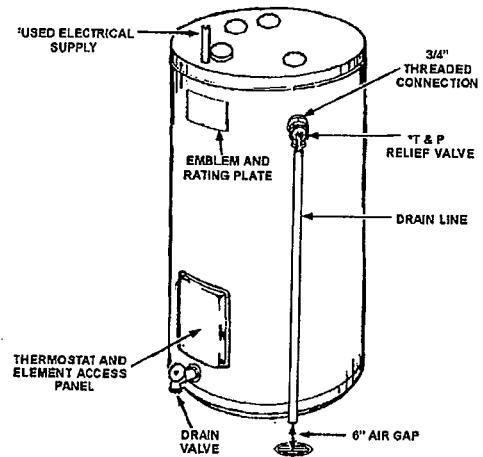
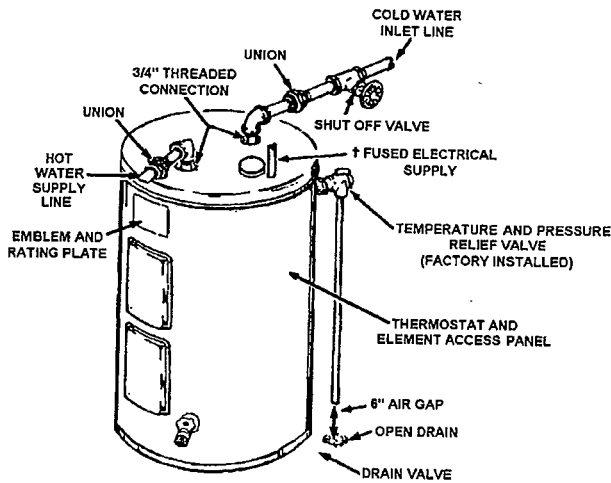

UPRIGHTS

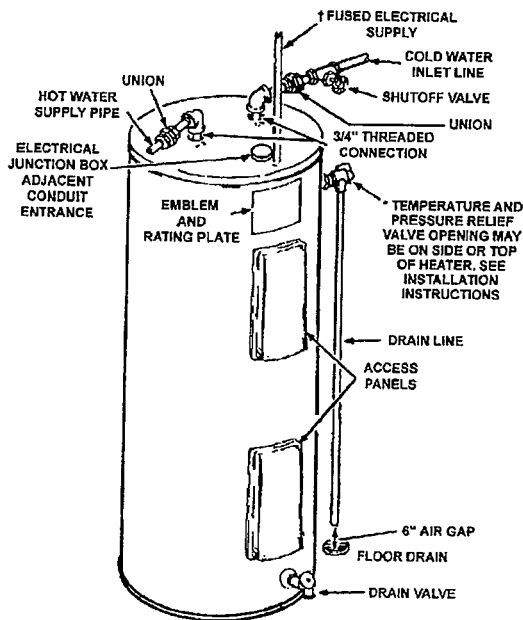

COMPACTS

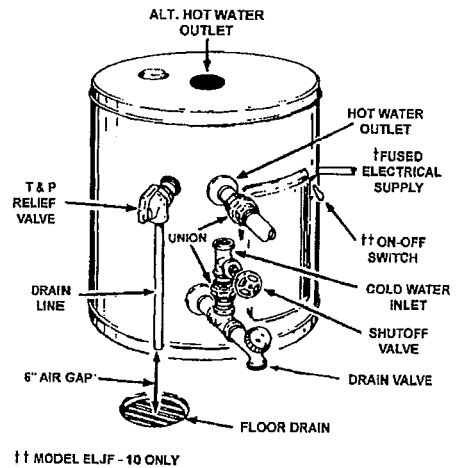
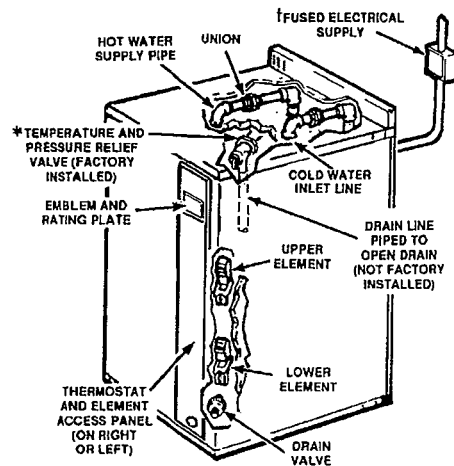

TABLE TOPS



INSTALL SUITABLE DRAIN PANS UNDER HEATERS TO PREVENT DAMAGE DUE TO LEAKAGE. REFER TO WATER HEATER LOCATION ON PAGE 8.



INSTALL VACUUM RELIEF IN COLD WATER INLET LINE AS REQUIRED BY LOCAL CODES.

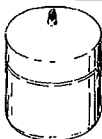

INSTALL THERMAL EXPANSION TANK OR DEVICE IF WATER HEATER IS INSTALLED IN A CLOSED WATER SYSTEM.

FIGURE 1.

WIRING DIAGRAMS



⚠ WARNING

- Before removing any access panels or servicing the water heater, make sure the electrical supply to the water heater is turned "OFF".
- Failure to do this could result in death, serious bodily injury, or property damage.

TURN OFF THE HEATER ELECTRICAL SUPPLY BEFORE SERVICING ANY ELECTRICAL COMPONENTS.

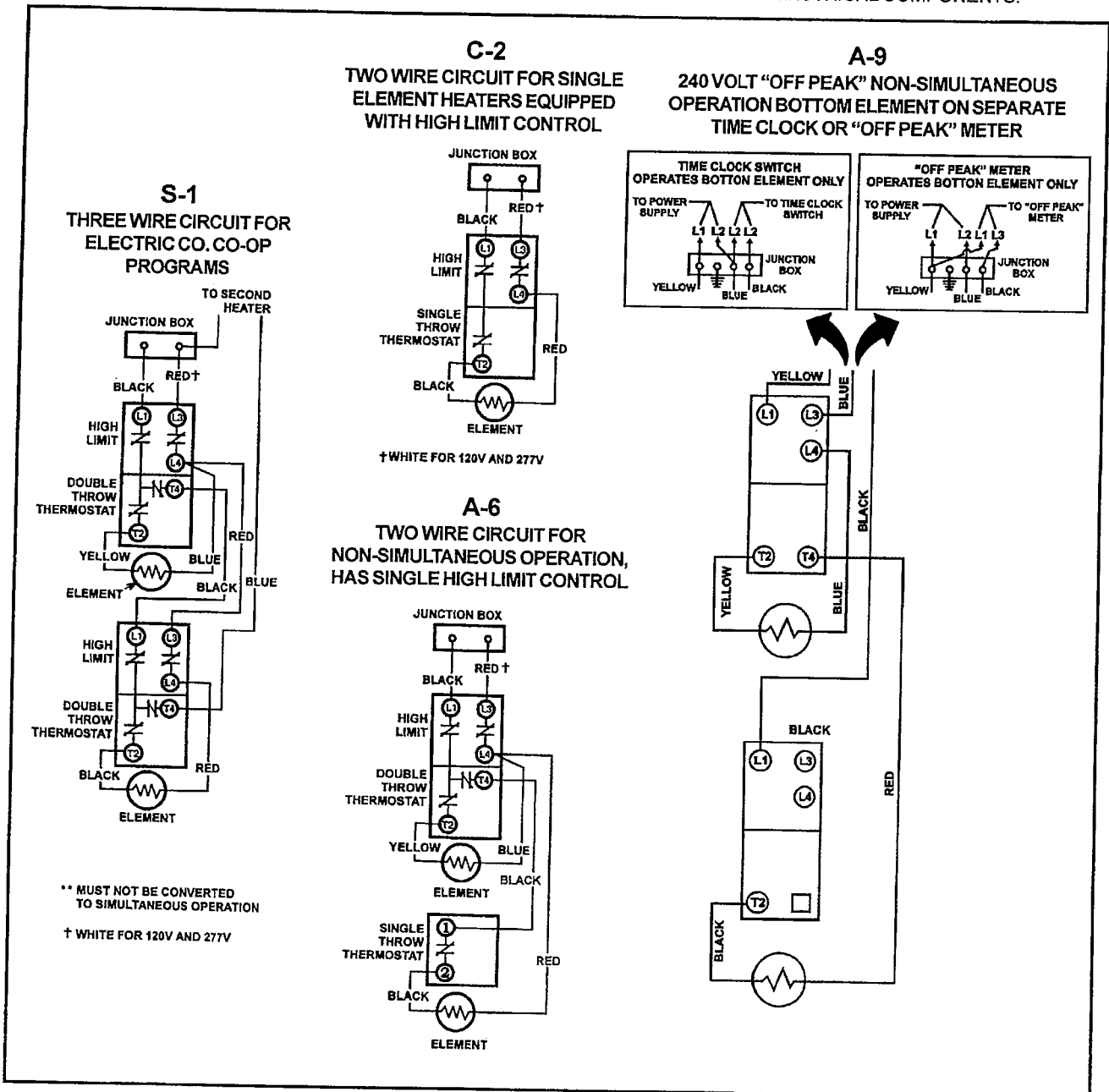

FIGURE 2.

MIXING VALVE USAGE

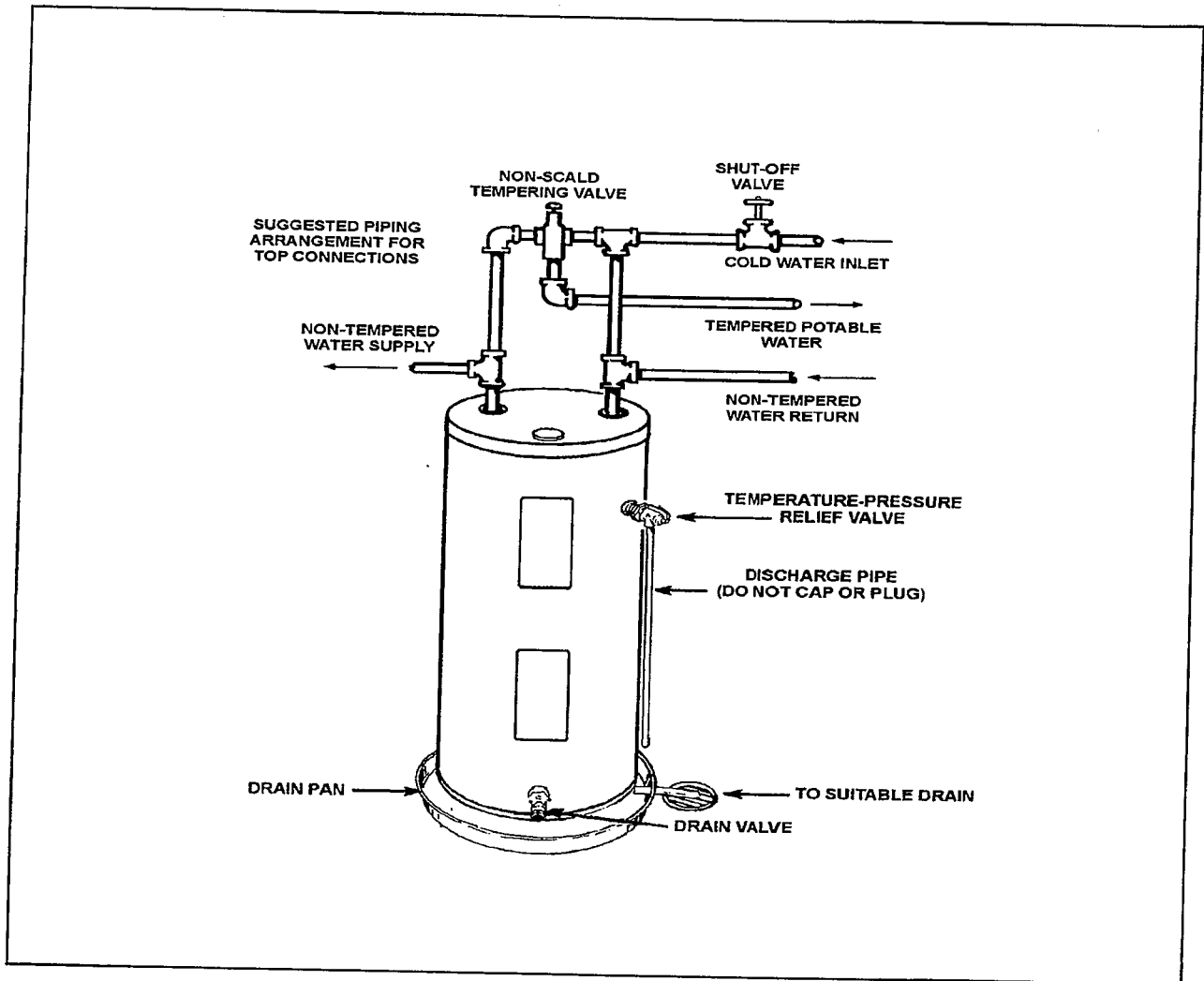

FIGURE 3.

Water (Potable) Heating: All models are considered suitable for water (potable) heating only.

HOTTER WATER CAN SCALD:

Water heaters are intended to produce hot water. Water heated to a temperature which will satisfy space heating, clothes washing, dish washing, and other sanitizing needs can scald and permanently injure you upon contact. Some people are more likely to be permanently injured by hot water than others. These include the elderly, children, the infirm, or physically/mentally handicapped. If anyone using hot water in your home fits into one of these groups or if there is a local code or state law requiring a certain temperature water at the hot water tap, then you must take special precautions. In addition to using the lowest possible temperature setting that satisfies your hot water needs, a means such as a *mixing valve, shall be used at the hot water taps used by these people or at the water heater. Mixing valves are available local plumbing contractor. Consult a Qualified Installer or Service Agency. Follow mixing valve manufacturer's instructions for installation of the valves. Before changing the factory setting on the thermostat, read the "Temperature Regulation" section in this manual.

	<p>▲ DANGER Water temperature over 125°F (52°C) can cause severe burns instantly resulting in severe injury or death.</p> <p>Children, the elderly, and the physically or mentally disabled are at highest risk for scald injury.</p> <p>Feel water before bathing or showering.</p> <p>Temperature limiting valves are available.</p> <p>Read instruction manual for safe temperature setting.</p>
--	--

LOCATING THE NEW WATER HEATER

FACTS TO CONSIDER ABOUT THE LOCATION

CAUTION

Property Damage Hazard

- All water heaters eventually leak
- Do not install without adequate drainage.

Carefully choose an indoor location for the new water heater, because the placement is a very important consideration for the safety of the occupants in the building and for the most economical use of the appliance.

Whether replacing an old water heater or putting the water heater in a new location, the following critical points must be observed:

1. Select a location indoors as close as practical or centralized to the water piping system as possible. The water heater should be located in an area not subject to freezing temperatures.
2. Selected location must provide adequate clearances (4") for servicing parts such as the thermostats, drain valve and relief valve. Adequate clearance for servicing this appliance should be considered before installation, such as changing the anodes, etc.

Installation of the water heater must be accomplished in such a manner that if the tank or any connections should leak, the flow will not cause damage to the structure. For this reason, it is not advisable to install the water heater in an attic or upper floor. When such locations cannot be avoided, a suitable drain pan should be installed under the water heater. Drain pans are available from your local plumbing contractor. Such a drain pan must have a minimum length and width of at least 2 inches (51 mm) greater than the water heater dimensions and must be piped to an adequate drain.

Water heater life depends upon water quality, water pressure and the environment in which the water heater is installed. Water heaters are sometimes installed in locations where leakage may result in property damage, even with the use of a drain pan piped to a drain. However, unanticipated damage can be reduced or prevented by a leak detector or water shut-off device used in conjunction with a piped drain pan. These devices are available from some plumbing supply wholesalers and retailers, and detect and react to leakage in various ways:

- Sensors mounted in the drain pan that trigger an alarm or turn off the incoming water to the water heater when leakage is detected.
- Sensors mounted in the drain pan that turn off the water supply to the entire home when water is detected in the drain pan.
- Water supply shut-off devices that activate based on the water pressure differential between the cold water and hot water pipes connected to the water heater.
- Devices that will turn off the gas supply to a gas water heater while at the same time shutting off its water supply.

INSULATION BLANKETS

Insulation blankets are available to the general public for external use on electric water heaters but are not necessary with this product. The purpose of an insulation blanket is to reduce the standby heat loss encountered with storage tank heaters. Your water heater meets or exceeds the National Appliance Energy Conservation Act standards with respect to insulation and standby loss requirements, making an insulation blanket unnecessary.

Should you choose to apply an insulation blanket to this heater, you should follow these instructions below. Failure to follow these instructions can result in fire, serious personal injury, or death.

- Do not cover the temperature and pressure relief (T & P) valve with an insulation blanket.
- Do not cover the instruction manual. Keep it on the side of the water heater or nearby for future reference.
- Do obtain new warning and instruction labels for placement on the blanket directly over the existing labels.

INSTALLING THE NEW WATER HEATER

WATER PIPING

▲ DANGER

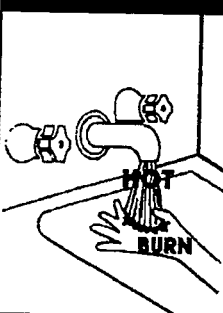

Water temperature over 125°F (52°C) can cause severe burns instantly resulting in severe injury or death.

Children, the elderly, and the physically or mentally disabled are at highest risk for scald injury.

Feel water before bathing or showering.

Temperature limiting valves are available.

Read instruction manual for safe temperature setting.

HOTTER WATER CAN SCALD:

Water heaters are intended to produce hot water. Water heated to a temperature which will satisfy space heating, clothes washing, dish washing, cleaning and other sanitizing needs can scald and permanently injure you upon contact. Some people are more likely to be permanently

injured by hot water than others. These include the elderly, children, the infirm, or physically/mentally handicapped. If anyone using hot water in your home fits into one of these groups or if there is a local code or state law requiring a certain temperature water at the hot water tap, then you must take special precautions. In addition to using the lowest possible temperature setting that satisfies your hot water needs, a means such as a *mixing valve, shall be used at the hot water taps used by these people or at the water heater. Valves for reducing point of use temperature by mixing cold and hot water are also available.

Consult a Qualified Installer or Service Agency. Follow manufacturer's instructions for installation of the valves. Before changing the factory setting on the thermostat, read the "Temperature Regulation" section in this manual.

▲ WARNING

Toxic Chemical Hazard

- Do not connect to non-potable water system.

This water heater shall not be connected to any heating systems or component(s) used with a non-potable water heating appliance.

Toxic chemicals, such as those used for boiler treatment shall not be introduced into this system.

Water supply systems may, because of such events as high line pressure, frequent cut-offs, the effects of water hammer among others, have installed devices such as pressure reducing valves, check valves, back flow preventers, etc. to control these types of problems. When these devices are not equipped with an internal by-pass, and no other measures are taken, the devices cause the water system to be closed. As water is heated, it expands (thermal expansion) and closed systems do not allow for the expansion of heated water.

The water within the water heater tank expands as it is heated and increases the pressure of the water system. If the relieving point of the water heater's temperature-pressure relief valve is reached, the valve will relieve the excess pressure. **The temperature-pressure relief valve is not intended for the constant relief of thermal expansion.** This is an unacceptable condition and must be corrected. It is recommended that any devices installed which could create a closed system have a by-pass and/or the system have an expansion tank or device to relieve the pressure built by thermal expansion in the water system. Expansion tanks are available for ordering through a local plumbing contractor. Contact the local water supplier and/or a service agency for assistance in controlling these situations.

NOTE: To protect against untimely corrosion of hot and cold water fittings, it is strongly recommended that di-electric unions or couplings be installed on this water heater when connected to copper pipe.

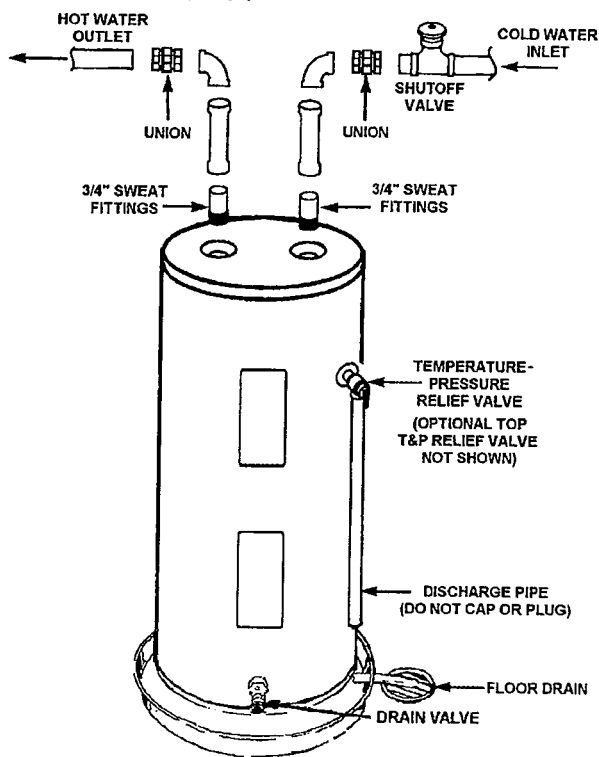

FIGURE 4.

Figure 4 shows the typical attachment of the water piping to the water heater. The water heater is equipped with 3/4 inch NPT water connections.

NOTE: If using copper tubing, solder tubing to an adapter before attaching the adapter to the cold water inlet connection. Do not solder the cold water supply line directly to the cold water inlet, it will harm the dip tube and damage the tank.

TEMPERATURE-PRESSURE RELIEF VALVE

⚠ WARNING

Explosion Hazard

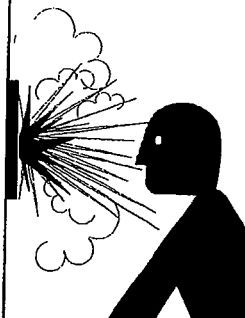

- Temperature-pressure relief valve must comply with ANSI Z21.22 and ASME code.
- Properly sized temperature-relief valve must be installed in opening provided.
- Can result in overheating and excessive tank pressure.
- Can cause serious injury or death.

This heater is provided with a properly certified combination temperature - pressure relief valve by the manufacturer.

CAUTION

Property Damage Hazard

- Avoid water heater damage.
- Install thermal expansion tank if necessary.
- Do not apply heat to cold water inlet.
- Contact qualified installer or service agency.

The valve is certified by a nationally recognized testing laboratory that maintains periodic inspection of production of listed equipment of materials as meeting the requirements for Relief Valves and Automatic Gas Shut-off Devices for Hot Water Supply Systems, ANSI Z21.22 • CSA 4.4, and the code requirements of ASME.

If replaced, the valve must meet the requirements of local codes, but not less than a combination temperature and pressure relief valve certified as indicated in the above paragraph.

The valve must be marked with a maximum set pressure not to exceed the marked hydrostatic working pressure of the water heater (150 psi = 1,035 kPa) and a discharge capacity not less than the water heater input rate as shown on the model rating plate.

For safe operation of the water heater, the relief valve must not be removed from its designated opening nor plugged.

The temperature-pressure relief valve must be installed directly into the fitting of the water heater designed for the relief valve. Position the valve downward and provide tubing so that any discharge will exit only within 6 inches (153 mm) above, or at any distance below the structural floor. Be certain that no contact is made with any live electrical part. The discharge opening must not be blocked or reduced in size under any circumstances. Excessive length, over 30 feet (9.14 m), or use of more than four elbows can cause restriction and reduce the discharge capacity of the valve.

No valve or other obstruction is to be placed between the relief valve and the tank. Do not connect tubing directly to discharge drain unless a 6 inch air gap is provided. To prevent bodily injury, hazard to life, or property damage, the relief valve must be allowed to discharge water in quantities should circumstances demand. If the discharge pipe is not connected to a drain or other suitable means, the water flow may cause property damage.

CAUTION
Water Damage Hazard
<ul style="list-style-type: none"> • Temperature-pressure relief valve discharge pipe must terminate at adequate drain.

The Discharge Pipe:

- Shall not be smaller in size than the outlet pipe size of the valve, or have any reducing couplings or other restrictions.
- Shall not be plugged or blocked.
- Shall be of material listed for hot water distribution.
- Shall be installed so as to allow complete drainage of both the temperature-pressure relief valve, and the discharge pipe.
- Shall terminate at an adequate drain.
- Shall not have any valve between the relief valve and tank.

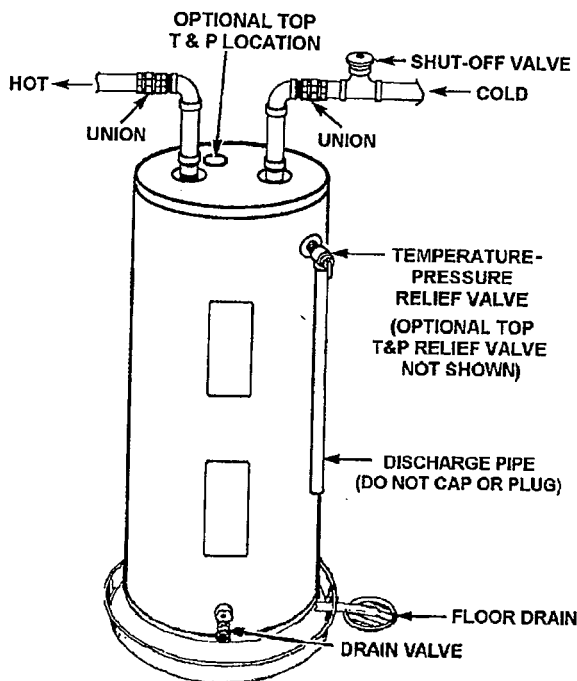

FIGURE 5.

⚠ DANGER	<p>Water temperature over 125°F (52°C) can cause severe burns instantly resulting in severe injury or death.</p> <p>Children, the elderly, and the physically or mentally disabled are at highest risk for scald injury.</p> <p>Feel water before bathing or showering.</p> <p>Temperature limiting valves are available.</p> <p>Read instruction manual for safe temperature setting.</p>

The temperature-pressure relief valve must be manually operated at least once a year. Caution should be taken to ensure that (1) no one is

in front of or around the outlet of the temperature-pressure relief valve discharge line, and (2) the water manually discharged will not cause any bodily injury or property damage because the water may be extremely hot.

If after manually operating the valve, it fails to completely reset and continues to release water, immediately close the cold water inlet to the water heater, follow the draining instructions, and replace the temperature-pressure relief valve with a new one.

FILLING THE WATER HEATER

CAUTION
Property Damage Hazard
<ul style="list-style-type: none"> • Avoid water heater damage. • Fill tank with water before operating.

Never use this water heater unless it is completely full of water. To prevent damage to the tank, the tank must be filled with water. Water must flow from the hot water faucet before turning "ON" electrical supply to the water heater.

To fill the water heater with water:

1. Close the water heater drain valve by turning the handle to the right (clockwise). The drain valve is on the lower front of the water heater.
2. Open the cold water supply valve to the water heater. **NOTE:** The cold water supply valve must be left open when the water heater is in use.
3. To insure complete filling of the tank, allow air to exit by opening the nearest hot water faucet. Allow water to run until a constant flow is obtained. This will let air out of the water heater and the piping.
4. Check all water piping and connections for leaks. Repair as needed.

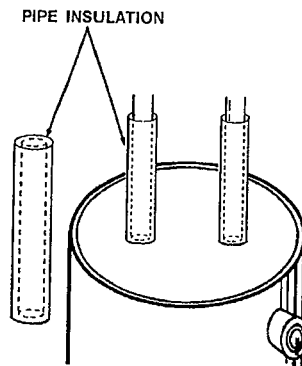

FIGURE 6.

T&P VALVE and PIPE INSULATION (On Selected Models)

Remove insulation for T&P Valve and pipe connections from carton.

Fit pipe insulation over the incoming cold water line and the hot water line. Make sure that the insulation is against the top cover of the heater.

Fit T&P Valve insulation over valve. Make sure that the insulation does not interfere with the lever or outlet of the T&P valve.

Secure all insulation using tape.

TEMPERATURE REGULATION

Due to the nature of the typical water heater, the water temperature in certain situations may vary up to 30°F (16.7 °C) higher or lower at the point of use such as, bathtubs, showers, sink, etc.

Any water heater's intended purpose is to heat water. Hot water is needed for cleansing, cleaning, and sanitizing (bodies, dishes, clothing). Untempered hot water can present a scald hazard. Depending on the time element, and the people involved (adults, children, elderly, infirm, etc.) scalding may occur at different temperatures.

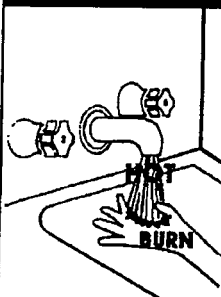

⚠ DANGER Water temperature over 125°F (52°C) can cause severe burns instantly resulting in severe injury or death.

Children, the elderly, and the physically or mentally disabled are at highest risk for scald injury.

Feel water before bathing or showering.

Temperature limiting valves are available.

Read instruction manual for safe temperature setting.

HOTTER WATER CAN SCALD: Water heaters are intended to produce hot water. Water heated to a temperature which will satisfy space heating, clothes washing, dish washing, and other sanitizing needs can scald and permanently injure you upon contact. Some people are more likely to be permanently injured by hot water than others. These include the elderly, children, the infirm, or physically/mentally handicapped. If anyone using hot water in your home fits into one of these groups or if there is a local code or state law requiring a certain temperature water at the hot water tap, then you must take special precautions. In addition to using the lowest possible temperature setting that satisfies your hot water needs, a means such as a mixing valve, shall be used at the hot water taps used by these people or at the water heater. Mixing valves are available from your local plumbing contractor. Follow manufacturer's instructions for installation of the valves. Before changing the factory setting on the thermostat, read the "Temperature Regulation" section in this manual.

THIS WATER HEATER IS EQUIPPED WITH AN ADJUSTABLE THERMOSTAT TO CONTROL WATER TEMPERATURE. HOT WATER TEMPERATURES DESIRED FOR AUTOMATIC DISHWASHER AND LAUNDRY USE CAN CAUSE SCALDS RESULTING IN SERIOUS PERSONAL INJURY AND/OR DEATH. THE TEMPERATURE AT WHICH INJURY OCCURS VARIES WITH THE PERSON'S AGE AND THE TIME OF THE EXPOSURE. THE SLOWER RESPONSE TIME OF CHILDREN, AGED OR DISABLED PERSONS INCREASES THE HAZARDS TO THEM. NEVER ALLOW SMALL CHILDREN TO USE A HOT WATER TAP, OR TO DRAW THEIR OWN BATH WATER. NEVER LEAVE A CHILD OR DISABLED PERSON UNATTENDED IN A BATHTUB OR SHOWER.

It is recommended that lower water temperatures be used to avoid the risk of scalding. It is further recommended, in all cases, that the water temperature thermostat (See Figure 3) be set for the lowest temperature which satisfies your hot water needs. This will also provide the most energy efficient operation of the water heater. Thermostat(s) are factory set at 120°F (49°C) unless specified differently by state requirements.

KEEPING THE THERMOSTAT SETTING AT 120°F WILL REDUCE THE RISK OF SCALDS.

Figure 7 shows the approximate time-to-burn relationship for normal adult skin. The thermostats on your water heater have a linear relationship between degrees of angular rotation and the corresponding change in temperature. Thus rotating the temperature adjustment indicator 30 angular degrees will result in a 10 degree Fahrenheit change in water temperature.

TEMPERATURE ADJUSTMENT



⚠ WARNING

- Before removing any access panels or servicing the water heater, make sure the electrical supply to the water heater is turned "OFF".
- Failure to do this could result in death, serious bodily injury, or property damage.

To change the temperature setting:

1. Turn off the heater electrical supply. Do not attempt to adjust thermostat with power on.
2. Remove the thermostat access panels and covers from the thermostats. Do not remove the plastic personnel protectors covering the thermostats.
3. Using a flat tip screwdriver, rotate the adjustment knob to the desired temperature setting.
4. Replace the covers and access panels and turn on heater electrical supply.

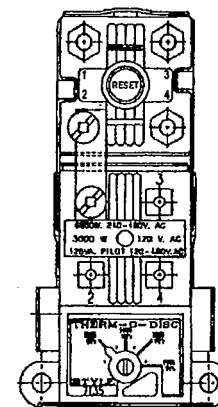
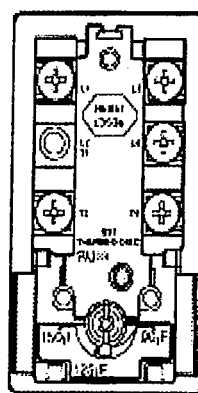

Temperature Settings	Time to Produce 2nd & 3rd Degree Burns on Adult Skin
160°F (71°C)	About 1/2 second
150°F (66°C)	About 1-1/2 seconds
140°F (60°C)	Less than 5 seconds
130°F (54°C)	About 30 seconds
120°F (49°C)	More than 5 minutes
80°F (27°C)	-----

FIGURE 7.

FOR YOUR INFORMATION

THERMAL EXPANSION

CAUTION

Property Damage Hazard

- Avoid water heater damage.
- Install thermal expansion tank or device if necessary.
- Contact qualified installer or service agency.

Water supply systems may, because of such events as high line pressure, frequent cut-offs, the effects of water hammer among others, have installed devices such as pressure reducing valves, check valves, back flow preventers, etc. to control these types of problems. When these devices are not equipped with an internal by-pass, and no other measures are taken, the devices cause the water system to be closed. As water is heated, it expands (thermal expansion) and closed systems do not allow for the expansion of heated water.

The water within the water heater tank expands as it is heated and increases the pressure of the water system. If the relieving point of the water heater's temperature-pressure relief valve is reached, the valve will relieve the excess pressure. **The temperature-pressure relief valve is not intended for the constant relief of thermal expansion.** This is an unacceptable condition and must be corrected. It is recommended that any devices installed which could create a closed system have a by-pass and/or the system have an expansion tank or device to relieve the pressure built by thermal expansion in the water system. Expansion tanks are available for ordering through a local plumbing contractor. Contact the local water heater supplier or service agency for assistance in controlling these situations.

STRANGESOUNDS

Possible noises due to expansion and contraction of some metal parts during periods of heat-up and cool-down do not necessarily represent harmful or dangerous conditions.

OPERATIONAL CONDITIONS

SMELLY WATER

In each water heater there is installed at least one anode rod (see parts sections) for corrosion protection of the tank. Certain water conditions will cause a reaction between this rod and the water. The most common complaint associated with the anode rod is one of a "rotten egg smell" in the hot water. This odor is derived from hydrogen sulfide gas dissolved in the water. The smell is the result of four factors which must all be present for the odor to develop:

- a. A concentration of sulfate in the supply water.
- b. Little or no dissolved oxygen in the water.

- c. A sulfate reducing bacteria which has accumulated within the water heater (this harmless bacteria is nontoxic to humans).
- d. An excess of active hydrogen in the tank. This is caused by the corrosion protective action of the anode.

Smelly water may be eliminated or reduced in some water heater models by replacing the anode(s) with one of less active material, and then chlorinating the water heater tank and all hot water lines. Contact the local water heater supplier or service agency for further information concerning an Anode Replacement Kit and this chlorination treatment. If the smelly water persists after the anode replacement and chlorination treatment, we can only suggest that chlorination or aeration of the water supply be considered to eliminate the water problem.

Do not remove the anode leaving the tank unprotected. By doing so, all warranty on the water heater tank is voided.

"AIR" IN HOT WATER FAUCETS

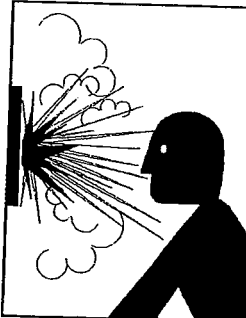

WARNING

Explosion Hazard

- Flammable hydrogen gases may be present.
- Keep all ignition sources away from faucet when turning on hot water.

HYDROGEN GAS: Hydrogen gas can be produced in a hot water system that has not been used for a long period of time (generally two weeks or more). Hydrogen gas is extremely flammable and explosive. To prevent the possibility of injury under these conditions, we recommend the hot water faucet, located farthest away, be opened for several minutes before any electrical appliances which are connected to the hot water system are used (such as a dishwasher or washing machine). If hydrogen gas is present, there will probably be an unusual sound similar to air escaping through the pipe as the hot water faucet is opened. There must be no smoking or open flame near the faucet at the time it is open.

HIGH WATER TEMPERATURE SHUT OFF SYSTEM

A non-adjustable high temperature limit control operates before steam temperatures are reached. The high limit is in the same area as the upper thermostat and must be reset manually when it operates. **BECAUSE THE HIGH LIMIT OPERATES ONLY WHEN ABNORMALLY HIGH WATER TEMPERATURES ARE PRESENT, IT IS IMPORTANT THAT A QUALIFIED SERVICE AGENT BE CONTACTED TO DETERMINE THE REASON FOR OPERATION BEFORE RESETTING.**

PERIODIC MAINTENANCE

ANODE ROD INSPECTION

CAUTION

Property Damage Hazard

- Avoid water heater damage.
- Inspection and replacement of anode rod required.

The anode rod is used to protect the tank from corrosion. Most hot water tanks are equipped with an anode rod. The submerged rod sacrifices itself to protect the tank. Instead of corroding the tank, water ions attack and eat away the anode rod. This does not affect the water's taste or color. The rod must be maintained to keep the tank in operating condition.

Anode deterioration depends on water conductivity, not necessarily water condition. A corroded or pitted anode rod indicates high water conductivity and should be checked and/or replaced more often than an anode rod that appears to be intact. Replacement of a depleted

anode rod can extend the life of your water heater. Inspection should be conducted by a qualified technician, and at a minimum should be checked annually after the warranty period.

TEMPERATURE-PRESSURE RELIEF VALVE OPERATION

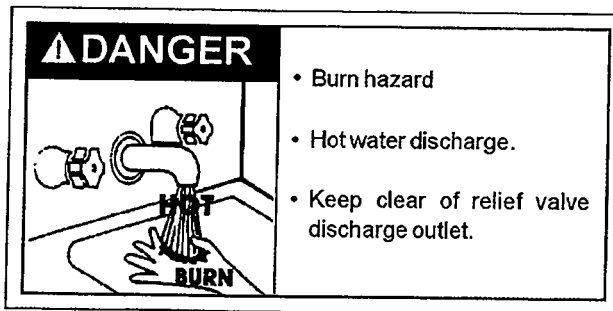

The temperature-pressure relief valve must be manually operated at least once a year.

When checking the temperature-pressure relief valve operation, make sure that (1) no one is in front of or around the outlet of the temperature-pressure relief valve discharge line, and (2) that the water discharge will not cause any property damage, as the water may be extremely hot, see Figure 8.

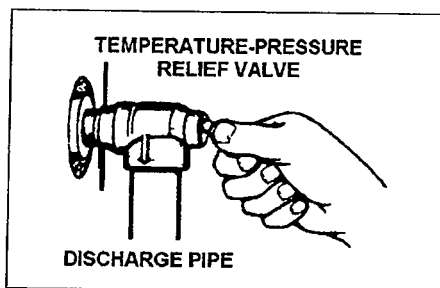
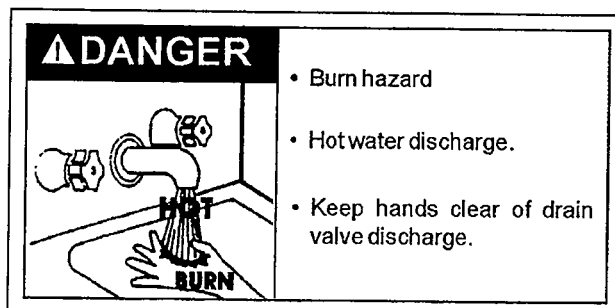

FIGURE 8.

If after manually operating the valve, it fails to completely reset and continues to release water, immediately close the cold water inlet to the water heater, follow the draining instructions, and replace the temperature-pressure relief valve with a new one.

If the temperature-pressure relief valve on the appliance weeps or discharges periodically, this may be due to thermal expansion. You may have a check valve installed in the water line or a water meter with a check valve. Consult your local water supplier or service agency for further information. Do not plug the temperature-pressure relief valve.

DRAINING



The water heater should be drained if being shut down during freezing temperatures. Also periodic draining and cleaning of sediment from the tank may be necessary.

1. Turn electrical supply "OFF".
2. CLOSE the cold water inlet valve to the water heater.
3. OPEN a nearby hot water faucet and leave open to allow for draining.
4. Connect a hose to the drain valve and terminate to an adequate drain.
5. OPEN the water heater drain valve to allow for tank draining.

NOTE: If the water heater is going to be shut down and drained for an extended period, the drain valve should be left open with hose connected allowing water to terminate to an adequate drain.

6. Close the drain valve.
7. Follow the instructions in the "Filling the Water Heater" section.

DRAIN VALVE WASHER REPLACEMENT

(See Figure 9)

1. Follow "Draining" instructions.
2. Turning counter clockwise (↺), remove the hex cap below the screw handle.
3. Remove the washer and put the new one in place.
4. Screw the handle and cap assembly back into the drain valve and retighten using a wrench. DO NOT OVER TIGHTEN.
5. Follow instructions in the "Filling The Water Heater" section.
6. Check for leaks.

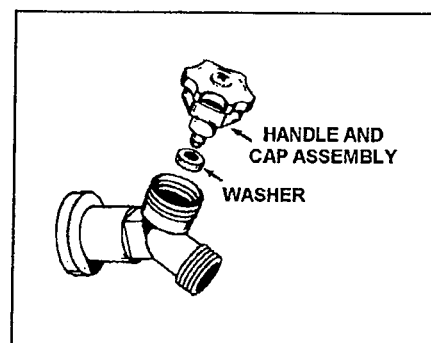

FIGURE 9.

SERVICE

If a condition persists or you are uncertain about the operation of the water heater contact a service agency.

Use this guide to check a "Leaking" water heater. Many suspected "Leakers" are not leaking tanks. Often the source of the water can be found and corrected.

If you are not thoroughly familiar with your water heater and safety practices, contact a qualified installer to check the water heater.

LEAKAGE CHECKPOINTS

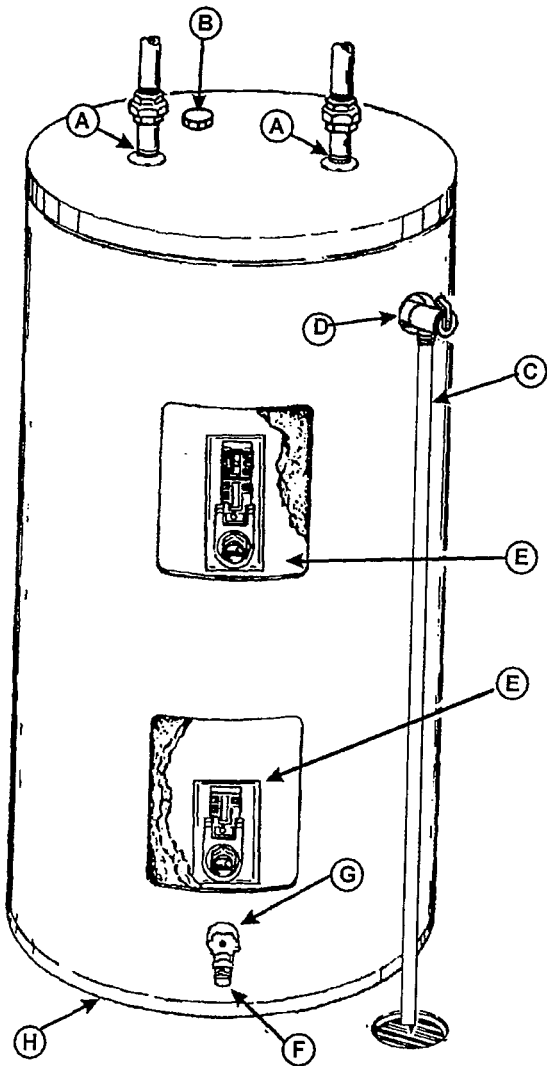

Read this manual first. Then before checking the water heater make sure the electrical power supply has been turned "OFF" before checking the tank for leakage.

- *A. Condensation and dripping may be seen on pipes if the water temperature is low in humid weather or pipe connections may be leaking.
- *B. The anode rod fitting may be leaking.
- C. Small amounts of water from temperature-pressure relief valve may be due to thermal expansion or high water pressure in your area. If the valve is not piped to an open drain the released water could be mistaken for a leaking heater.
- *D. The temperature-pressure relief valve may be leaking at the tank fitting.
- E. Water on the side of the tank may be condensation due to the panel or insulation not being in place.
- F. Water from a drain valve may be due to the valve being slightly opened.
- *G. The drain valve may be leaking at the tank fitting.
- *H. Water in the water heater bottom or on the floor may be from condensation, loose connections, or the relief valve. **DO NOT** replace the water heater until a full inspection of all possible water sources is made and necessary corrective steps taken.

Leakage from other appliances, water lines, or ground seepage should also be checked.

- * To check where threaded portion enters tank, insert cotton swab between jacket opening and fitting. If cotton is wet, follow "Draining" instructions in the "Periodic Maintenance" section and then remove fitting. Put pipe dope or teflon tape on the threads and replace. Then follow "Filling the Water Heater" instructions in the "Installing the New Water Heater" section.

	⚠ WARNING
	Read and understand instruction manual and safety messages before installing, operating or servicing this water heater.
	Failure to follow instructions and safety messages could result in death or serious injury. Instruction Manual must remain with water heater.

	⚠ WARNING
	<ul style="list-style-type: none"> • Before removing any access panels or servicing the water heater, make sure the electrical supply to the water heater is turned "OFF".
	<ul style="list-style-type: none"> • Failure to do this could result in death, serious bodily injury, or property damage.

REPAIR PARTS LIST

Key No.	Part Description
1	Upper Heating Element (If Dual Element Unit)
2	Lower Heating Element
3	Element Gasket
4	Lower Thermostat (If Dual Element Unit)
5	Upper Thermostat w/ECO (If Dual Element Unit)
6	Lower Thermostat w/ECO (If Single Element Unit)
7	Outer Door(s)
8	Inlet Tube
9	Drain Valve
10	Drain Valve Washer
11	Anode Rod
12	Anode Outlet/Heat Trap (If Applicable)
13	Temperature-Pressure Relief Valve
14	External Heat Trap Nipples (If Applicable)
15	Pipe Insulation (If Applicable)
16	T&P Insulation (If Applicable)
17	Drain Pan w/Side Drain
*	Instruction Manual

*Not Illustrated

Now that you have purchased this water heater, should a need ever exist for repair parts or service, simply contact the company it was purchased from or the manufacturer listed on the rating plate on the water heater.

Be sure to provide all pertinent facts when you call or visit.

Selling prices will be furnished on request or parts will be shipped at prevailing prices and you will be billed accordingly.

The model number of your Water Heater will be found on the rating place located above or adjacent to outer door.

WHEN ORDERING REPAIR PARTS, ALWAYS GIVE THE FOLLOWING INFORMATION:

- MODEL NUMBER
- SERIAL NUMBER
- PART DESCRIPTION

THIS IS A REPAIR PARTS LIST, NOT A PACKING LIST.

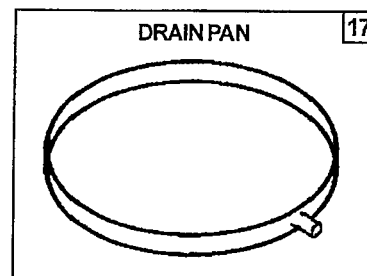
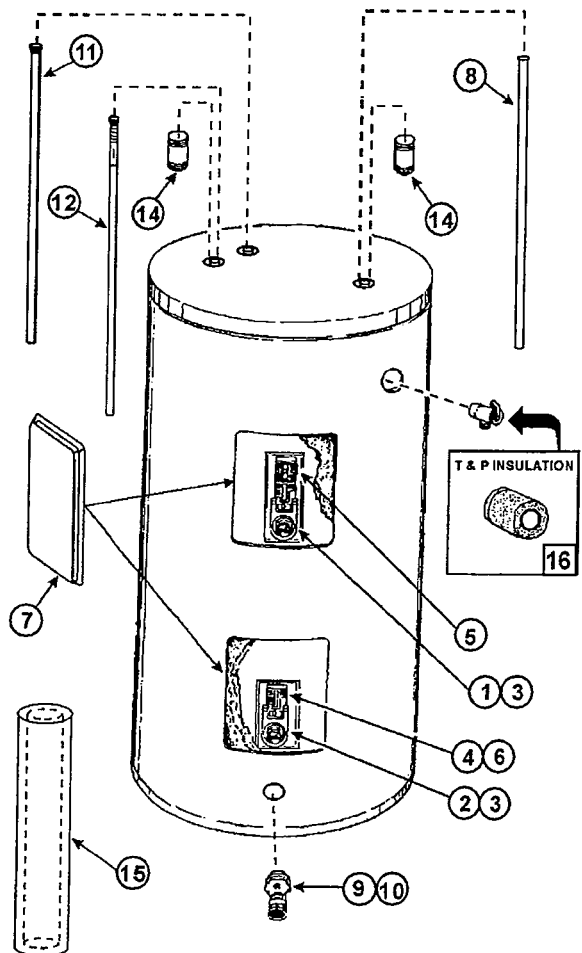

A.O. Smith
Water Heaters

www.aosmithwaterheaters.com

TROUBLESHOOTING GUIDELINES

These guidelines should be utilized by a qualified service agent.

Problem	Cause	Solution
WATER LEAKS (See Leakage Checkpoints on 14)	Improperly sealed, hot or cold supply connection, relief valve or drain valve.	Tighten threaded connections.
	Leakage from other appliances or water lines.	Inspect other appliances near water heater.
LEAKING TEMPERATURE AND PRESSURE RELIEF VALVE	Thermal expansion in closed water system.	Install thermal expansion tank (DO NOT plug T&P valve).
	Improperly seated valve.	Check relief valve for proper operation (DO NOT plug T&P valve).
HOT WATER ODORS (CAUTION: UNAUTHORIZED REMOVAL OF THE ANODE(S) WILL VOID THE WARRANTY FOR FURTHER INFORMATION, CONTACT YOUR DEALER)	High sulfate or mineral content in water supply.	Drain and flush heater thoroughly, then refill.
	Bacteria in water supply.	Chlorinate water supply.
NOT ENOUGH OR NO HOT WATER	Power supply to heater is not on.	Turn disconnect switch on or contact electrician.
	Thermostat set too low.	Refer to temperature regulation.
	Heater undersized.	Reduce hot water use.
	Incoming water is usually cold (Winter).	Allow more time for heat to reheat.
	Leaking hot water from pipes or fixtures.	Have plumber check and repair leaks.
	High temperature limit switch activated.	Contact dealer to determine cause. See temperature regulation.
HOT WATER TOO HOT	Thermostat set too high.	Refer to temperature regulation.
	High temperature limit switch activated.	Contact dealer to determine cause. See temperature regulation.
WATER HEATER SOUNDS	Scale accumulation on elements.	Contact dealer to clean or replace elements.
	Sediment build-up on tank bottom.	Drain and flush heater thoroughly, then refill.

A.O. Smith Water Heaters

RESIDENTIAL ELECTRIC WARRANTY

THIS WARRANTY IS APPLICABLE TO THE ORIGINAL OWNER ONLY. In accordance with the warranty terms and conditions specified below.

A. O. Smith Water Heaters (the warrantor) will furnish the ORIGINAL OWNER, 1) a replacement A. O. Smith water heater of equivalent size and current model if the glasslined tank in this water heater leaks and, 2) a replacement part for any component part which fails.

THE A. O. SMITH WATER HEATERS REPLACEMENT MODEL OR PART WILL BE WARRANTED FOR ONLY THE UNEXPIRED PORTION OF THE ORIGINAL WARRANTY. The warranty period will be determined by the original date of purchase of the water heater, or in the absence of a Bill of Sale verifying said date, from the date of manufacture indicated on rating plate affixed to this water heater. This warranty is not transferrable and applies to models listed below:

Series	Tank	Parts
Conservationist®	10-year	10-year
PXHT, PXHS		
ProMax® 10-Year Models	10-year	6-year
PCRT, PCRS, PCT, PCS, PCL, PCJ, PLJC, PLSC		
ProMax® 6-Year Models	6-year	6-year
ECRT, ECRS, ECT, ECS, ECL, ECJ, ELJC, ESTT, ELSC, ECLN, ECJN		

When the water heater has been used for other than single family residential application;

1. The tank warranty shall be reduced to 1 year for 6 year models and to 3 years for 10 year models.
2. The parts warranty shall be reduced to 1 year for all models.

CONDITIONS AND EXCEPTIONS

This warranty shall apply only when the water heater is installed and operated in accordance with 1) all local fire codes and plumbing codes, ordinances and regulations, 2) the printed instructions provided with it, 3) good industry practices, and 4) proper safety practices such as but not limited to a properly sized drain pan if installed in an area where leakage from the tank or its connections would result in damage to the area adjacent to the heater. In addition, a new temperature and pressure relief valve, certified by the Canadian Gas Association must have been properly installed and piped to the nearest drain.

This warranty shall apply only when the heater is:

- owned by the original purchaser;
- installed for indoor operation only;
- used at temperatures not exceeding the maximum calibrated setting of its thermostat;
- used at water pressure not exceeding the working pressure shown on the heater;
- filled with potable water, free to circulate at all times and with the tank free of damaging water sediment or scale deposits;
- used in a non-corrosive and non-contaminated atmosphere;
- used with factory approved anode(s) installed;
- in its original installation location;
- in the United States, its territories or possessions, and Canada;
- sized in accordance with proper sizing techniques for residential water heaters;
- bearing a rating plate which has not been altered, defaced or removed except as required by the warrantor;
- used in an open system or in a closed system with a properly sized and installed thermal expansion tank;
- connected to the proper voltage or:
- operated at the factory rated input;
- installed with no attempted, nor actual modification or alteration of the water heater's design in any way, including but not limited to, the attachment of non-company approved appliances or equipment.

Any accident to the water heater or any part thereof (including freezing, fire, floods, or lightning), any misuse, abuse or alteration of it, any operation of it in a modified form, any operation of the water heater on desalinated (deionized) water, or any damage caused by attempts to repair tank leaks or parts, will void this warranty. This warranty does not cover water heaters replaced for cosmetic reasons or for reasons of noise, taste, odor, discolored and/or rusty water. This warranty does not apply to water heaters used to heat pools, whirlpools or hot tubs or used for space heating where its sizing does not conform with specifications of the heating component manufacturer.

This warranty gives you specific legal rights, and you may have other rights which vary under the laws of each state. If any provision of this warranty is prohibited or invalid under applicable state law, that provision shall be ineffective to the extent of the prohibition or invalidity

without invalidating the remainder of the affected provision or the other provisions of this warranty.

SERVICE AND LABOR RESPONSIBILITY

UNDER THIS LIMITED WARRANTY, THE WARRANTOR WILL PROVIDE ONLY A REPLACEMENT WATER HEATER OR PART THEREOF. THE OWNER IS RESPONSIBLE FOR ALL OTHER COSTS. Such costs may include but are not limited to:

- a. Labor charges for service, removal, or reinstallation of the water heater or part thereof.
- b. Shipping and delivery charges for forwarding the new water heater or replacement part from the nearest distributor and returning the claimed defective heater or part to such distributor.
- c. All cost necessary or incidental for handling and administrative charges, and for any materials and/or permits required for installation of the replacement heater or part.

LIMITATION ON IMPLIED WARRANTIES

Implied warranties, including any warranty of merchantability imposed on the sale of this heater under state law are limited to one year duration for the heater or any of its parts. Some states do not allow limitations on how long an implied warranty lasts, so the above limitations may not apply to you.

CLAIM PROCEDURE

Any claim under this warranty should be initiated with the dealer who sold the heater, or with any other dealer handling the warrantor's products. If this is not practical, the owner should contact: A.O. Smith Corporation, 5621 W. 115th Street, Alsip, Illinois 60803. Phone: 1.800.323.2636 or visit our website: www.hotwater.com.

For Canadian customers contact: A.O. Smith Enterprises LTD., P.O. Box 310, 768 Erie Street, Stratford, Ontario N5A6T3 or phone: 1.800.265.8520

Replacement Parts may be ordered through authorized servicers or distributors. Refer to your local Yellow Pages for where to call or contact A.O. Smith Corporation, 5621 W. 115th Street, Alsip, Illinois 60803. Phone: 1.800.433.2545 or visit our website at: www.hotwater.com/parts.

The warrantor will only honor replacement with identical or similar water heater or parts thereof which are manufactured or distributed by the warrantor.

Dealer replacements are made subject to in-warranty validation by warrantor.

PROOF OF PURCHASE AND PROOF OF INSTALLATION DATE ARE REQUIRED TO SUPPORT WARRANTY CLAIM FROM ORIGINAL OWNER. THIS FORM DOES NOT CONSTITUTE PROOF OF PURCHASE OR PROOF OF INSTALLATION.

DISCLAIMERS

NO EXPRESSED WARRANTY HAS BEEN OR WILL BE MADE IN BEHALF OF THE WARRANTOR WITH RESPECT TO THE MERCHANTABILITY OF THE HEATER OR THE INSTALLATION, OPERATION, REPAIR OR REPLACEMENT OF THE HEATER OR PARTS. THE WARRANTOR SHALL NOT BE RESPONSIBLE FOR WATER DAMAGE, LOSS OF USE OF THE UNIT, INCONVENIENCE, LOSS OR DAMAGE TO PERSONAL PROPERTY, OR OTHER CONSEQUENTIAL DAMAGE. THE WARRANTOR SHALL NOT BE LIABLE BY VIRTUE OF THIS WARRANTY OR OTHERWISE FOR DAMAGE TO ANY PERSONS OR PROPERTY, WHETHER DIRECT OR INDIRECT, AND WHETHER ARISING IN CONTRACT OR IN TORT.

Should governmental regulations or industry standards prohibit the Manufacturer from furnishing a comparable model replacement under this warranty, the Owner will be furnished with the closest comparable water heater meeting the then current governmental regulations and industry standards. A supplementary fee may be assessed to cover the additional cost associated with the changes made to meet applicable regulations and standards.

IMPORTANT INFORMATION

Model Number _____

Serial Number _____

INSTALLATION INFORMATION

Date Installed _____

Company's Name _____

Street or P.O. Box _____

City, State, and Zip Code _____

Phone Number _____

Plumber's Name _____

A.O. Smith
Water Heaters

www.aosmithwaterheaters.com

A.O. Smith
Water Heaters

www.aosmithwaterheaters.com

110.3 Examination, Identification, Installation, and Use of Equipment

(B) Installation and Use. Listed or labeled equipment shall be installed and used in accordance with any instructions included in the listing or labeling.

422.13 Storage-Type Water Heaters

A fixed storage-type water heater that has a capacity of 450 L (120 gal) or less shall be considered a continuous load for the purposes of sizing branch circuits.

Informational Note: For branch-circuit rating, see 422.10.

Because certain water heaters are a continuous load, the branch circuit overcurrent device and conductors are required to be sized based on 125 percent of the water heater nameplate rating unless the overcurrent device and the assembly it is installed in are listed to be used at 100 percent of its continuous current rating

422.16 Flexible Cords

(A) General. Flexible cord shall be permitted (1) for the connection of appliances to facilitate their frequent interchange or to prevent the transmission of noise or vibration or (2) to facilitate the removal or disconnection of appliances that are fastened in place, where the fastening means and mechanical connections are specifically designed to permit ready removal for maintenance or repair and the appliance is intended or identified for flexible cord connection.

422.61 Marking of Heating Elements

All heating elements that are rated over one ampere, replaceable in the field, and a part of an appliance shall be legibly marked with the ratings in volts and amperes, or in volts and watts, or with the manufacturer's part number

Rheem ELECTRIC WATER HEATERS Installation Instructions & Owner's Manual Page 7

CONNECTIONS - ELECTRICAL

The electrical installation must be completed in accordance with AS/NZS 3000. All water heaters are designed for 230 VAC, 50 Hz mains operation and a means of disconnection from the power supply must be incorporated in the fixed wiring during installation. A flexible 20 mm conduit is required for the electrical cable to the water heater. The conduit is to be connected to the unit with a 20 mm plain to screw adaptor. Connect the power supply wires directly to the terminal block and earth tab connection, ensuring there are no excess wire loops inside the front cover. For details, refer to the wiring diagram on the inside of the element cover. A separate heating element earth wire is not required because the element earths by the flange being in contact with the element socket.

ELEMENT WIRING

All 325 model series are pre-wired for standard installations where the bottom element only is connected to the mains supply. For alternative energy configurations that require a smaller hot water boost volume, the upper element may be connected instead. The upper element is not factory fitted. For alternative energy installations the following element kitsets are available:

KITSET

DESCRIPTION

Kitset Element Solar / HP Droopy 2.0 kW

318241

Kitset Element Solar / HP Sickle 2.0 kW

318242

Kitset Element Solar / HP Sickle 3.0 kW

318243

CONNECTIONS – ALTERNATIVE ENERGY

TEMPERATURE SENSOR TUBE

Some models include receptacle tubes for temperature sensors used in alternative energy source

water heater products that may be connected to this cylinder. Ensure that any additional sensor wiring

is routed away from mains wiring and in accordance with the instructions provided by the manufacturer.

UL 174

Standard for Household Electric Storage Tank Water Heaters

[Purchase UL 174](#)

DETAILS

Edition Number:	11	SCC Approved:	--
Edition Date:	2004-04-29	DOD Approved:	--
Price Code:	<u>D</u>	ANSI Approved:	2016-12-15
Type:	ulstd		

- SCOPE

1 Scope

1.1 These requirements cover household electric storage tank and small capacity storage tank water heaters rated no more than 600 volts and 12 kilowatts to be installed in accordance with the National Electrical Code, NFPA 70, and with model plumbing and mechanical codes.

1.2 These requirements do not cover immersed electrode, side arm, booster, instantaneous or immersion type water heaters or water heating portions of water dispensing appliances. These requirements do not cover water heaters with a tank capacity of less than 1 gallon (3.8 L) or more than 120 gallons (454 L).

1.3 Electric booster water heaters, electric commercial storage tank water heaters, and remote control assemblies for such heaters, rated 600 volts or less are not covered by this standard. They are covered in the Standard for Electric Booster and Commercial Storage Tank Water Heaters, UL 1453.

1.4 Permanently installed electric water heaters, rated 600 volts or less, for heating the water supplied through plumbing to separately heated public or private pools or tubs, in which swimming, wading, bathing, or partial or total immersion of persons, is to be involved are not covered by this standard. They are covered in the Standard for Electric Water Heaters for Pools and Tubs, UL 1261.

1.5 Water heaters rated 600 volts or less with a tank capacity of less than 1 gallon (3.8 liters) are not covered by this standard. They are covered under the Standard for Electric Heating Appliances, UL 499.

1.6 A water heater intended for use in a hazardous location is to be judged on the basis of its compliance with these requirements; however, further examination and testing shall be conducted to determine whether it is acceptable for the intended use.

UL PRODUCT CATEGORY

[Heaters and Heating Equipment] (Water Heaters) Household Water Heaters, Storage Tank, KSDT

[See General Information for Water Heaters](#)

USE AND INSTALLATION

This category covers storage tank water heaters rated 600 V or less and 12 kW or less and having a tank capacity of more than one gal and not more than 120 gals.

This category does not cover immersed electrode, side arm, booster, instantaneous or immersion-type water heaters or water-heating portions of water-dispensing appliances.

These water heaters are intended for household use and permanent connection to the supply source in accordance with ANSI/NFPA 70, "National Electrical Code."

Household storage tank water heaters are equipped with a temperature-regulating device intended to restrict the water temperature to a maximum of 85°C (185°F). This device has been preset at the factory to a maximum setting of 51.7°C (125°F). These heaters are also equipped with a manually reset temperature-limit control that restricts the water temperature to a maximum of 99°C (210°F) should a regulating control fail.

Safety devices, such as temperature-pressure-relief mechanisms, are not required to be furnished as part of the certified water heater, but markings and instructions accompany each water heater indicating that a suitable safety device which complies with the local plumbing codes shall be connected to the heater at the time it is installed.

PRODUCT MARKINGS

Water heaters in accordance with Part 3280.707(d) (1) of HUD Mobile Home Construction and Safety Standards for Energy Efficiency are marked "Design evaluated by UL in accordance with Part 3280.707(d) (1) of HUD Mobile Home Construction and Safety Standards for Energy Efficiency."

PRODUCT IDENTITY

The following product identity appears on the product:

Household Storage Tank Water Heater

Other product identities may be used as shown in the individual certifications.

RELATED PRODUCTS

Water heaters intended for use in marine environments are covered under Water Heaters, Marine (LXWW).

Solar-electric water heaters are covered under Alternative-energy Water-storage Tanks and Multi-energy and Indirect Water Heaters (UZWZ).

ADDITIONAL INFORMATION

For additional information, see Electrical Equipment for Use in Ordinary Locations (AALZ), Heating, Cooling, Ventilating and Cooking Equipment (AAHC) and Plumbing and Associated Products (AAPP).

REQUIREMENTS

The basic standard used to investigate products in this category is ANSI/UL 174, "Household Electric Storage Tank Water Heaters."

UL MARK

The Certification Mark of UL on the product is the only method provided by UL to identify products manufactured under its Certification and Follow-Up Service. The Certification Mark for these products includes the UL symbol, the words "CERTIFIED" and "SAFETY," the geographic identifier(s), and a file number.

Alternate UL Mark

The Listing Mark of UL on the product is the only method provided by UL to identify products manufactured under its Listing and Follow-Up Service. The Listing Mark for these products includes the UL symbol (as illustrated in the Introduction of this Directory) together with the word "LISTED," a control number, and the product name "Household Storage Tank Water Heater," or other appropriate product name as shown in the individual Listings.

UL, in performing its functions in accordance with its objectives, does not assume or undertake to discharge any responsibility of the manufacturer or any other party. UL shall not incur any obligation or liability for any loss, expense or damages, including incidental or consequential damages, arising out of or in connection with the use, interpretation of, or reliance upon this Guide Information.

Last Updated on 2013-05-16

The appearance of a company's name or product in this database does not in itself assure that products so identified have been manufactured under UL's Follow-Up

Service. Only those products bearing the UL Mark should be considered to be Certified and covered under UL's Follow-Up Service. Always look for the Mark on the product.

UL permits the reproduction of the material contained in the Online Certification Directory subject to the following conditions: 1. The Guide Information, Assemblies, Constructions, Designs, Systems, and/or Certifications (files) must be presented in their entirety and in a non-misleading manner, without any manipulation of the data (or drawings). 2. The statement "Reprinted from the Online Certifications Directory with permission from UL" must appear adjacent to the extracted material. In addition, the reprinted material must include a copyright notice in the following format: "© 2019 UL LLC".

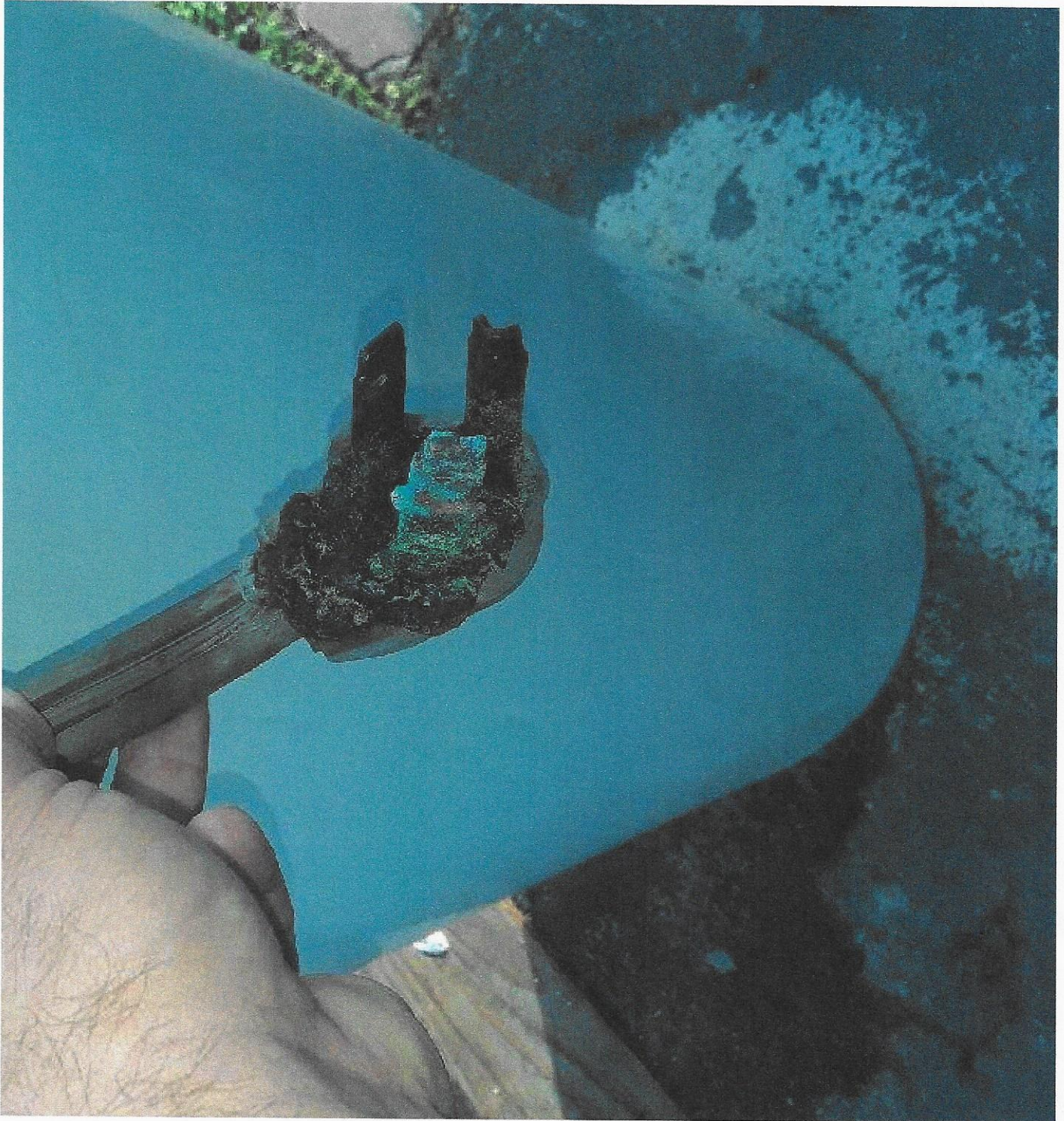

Kong, Maria

From: Dipietro, James
Sent: Thursday, October 24, 2019 3:59 PM
To: 'Gregg D'Attile'
Cc: Kong, Maria; Vinas, Otto; Castronovo, Kenneth
Subject: FW: Electronic Permitting

Gregg. I am asking Pat to place your request as an agenda item for the joint plumbing - electrical committee November 19 session. Please test your idea with discussing the water heater example and remember that electronic payments will be another factor to be worked out in time, should the committees wish to move forward on your suggestion. Thank you. Jim

Jim DiPietro
 Administrative Director
 Broward County Board of Rules and Appeals
 1 North University Drive, Suite 3500 B
 Plantation FL 33324
 954-765-4500 X9892
 954-931-2393 (cell)

-----Original Message-----

From: ArtCanFixIt <greggd@artcanfixit.com>
 Sent: Wednesday, October 23, 2019 5:02 PM
 To: Dipietro, James <JDIPIETRO@broward.org>
 Subject: Electronic Permitting

External Email

Jim,

Here is a follow up for inclusion in the joint Plumbing and Electrical meeting, we need to find a way that all the building departments in Broward County accept electronic permit applications for as many jobs as possible such as

Water heater change outs
 AC system change outs
 Sewer and water main replacements
 Back-flow Preventer replacements and testing HVAC duct system replacements Electric panel replacements Whole home generator installs Roofing And many other items.

A contractor should not have to drop off and pick up permits in the year 2019! The cost to the consumer and the contractor to file deliver and pick up permits is astronomical and unnecessary, elides all the liability of driving and the carbon emissions.

Further Broward County MUST crack down on unlicensed people doing work for which certified licensed contractors have to jump through hoops to be in business. Unlicensed people are costing the

Cities and Counties millions of dollars in lost permit revenue as well subjecting the public unscrupulous predatory people that lie steal and cheat.

Any questions let me know.

Gregg D'Attile
President/CEO
Art Plumbing AC & Electric
4151 NW 124 Ave
Coral Springs, FL 33065
954-752-1282
The "World's Greatest Company"
"We Can Fix It!"

Select Year:

The 2019 Florida Statutes

Title XXXIII
REGULATION OF TRADE, COMMERCE,
INVESTMENTS, AND SOLICITATIONS

Chapter 553
BUILDING CONSTRUCTION
STANDARDS

View Entire
Chapter

553.79 Permits; applications; issuance; inspections.—

(1)(a) After the effective date of the Florida Building Code adopted as herein provided, it shall be unlawful for any person, firm, corporation, or governmental entity to construct, erect, alter, modify, repair, or demolish any building within this state without first obtaining a permit therefor from the appropriate enforcing agency or from such persons as may, by appropriate resolution or regulation of the authorized state or local enforcing agency, be delegated authority to issue such permits, upon the payment of such reasonable fees adopted by the enforcing agency. The enforcing agency is empowered to revoke any such permit upon a determination by the agency that the construction, erection, alteration, modification, repair, or demolition of the building for which the permit was issued is in violation of, or not in conformity with, the provisions of the Florida Building Code. Whenever a permit required under this section is denied or revoked because the plan, or the construction, erection, alteration, modification, repair, or demolition of a building, is found by the local enforcing agency to be not in compliance with the Florida Building Code, the local enforcing agency shall identify the specific plan or project features that do not comply with the applicable codes, identify the specific code chapters and sections upon which the finding is based, and provide this information to the permit applicant. A plans reviewer or building code administrator who is responsible for issuing a denial, revocation, or modification request but fails to provide to the permit applicant a reason for denying, revoking, or requesting a modification, based on compliance with the Florida Building Code or local ordinance, is subject to disciplinary action against his or her license pursuant to s. 468.621(1)(i). Installation, replacement, removal, or metering of any load management control device is exempt from and shall not be subject to the permit process and fees otherwise required by this section.

(b) A local enforcement agency shall post each type of building permit application on its website. Completed applications must be able to be submitted electronically to the appropriate building department. Accepted methods of electronic submission include, but are not limited to, e-mail submission of applications in portable document format or submission of applications through an electronic fill-in form available on the building department's website or through a third-party submission management software. Payments, attachments, or drawings required as part of the permit application may be submitted in person in a nonelectronic format, at the discretion of the building official.

(c) A local government that issues building permits may send a written notice of expiration, by e-mail or United States Postal Service, to the owner of the property and the contractor listed on the permit, no less than 30 days before a building permit is set to expire. The written notice must identify the permit that is set to expire and the date the permit will expire.

(2) Except as provided in subsection (6), an enforcing agency may not issue any permit for construction, erection, alteration, modification, repair, or demolition of any building or structure until the local building code administrator or inspector has reviewed the plans and specifications required by the Florida Building Code, or local amendment thereto, for such proposal and found the plans to be in compliance with the Florida Building Code. If the local building code administrator or inspector finds that the plans are not in compliance with the Florida Building Code, the local building code administrator or inspector shall identify the specific plan features that do not comply with the applicable codes, identify the specific code chapters and sections upon which the finding is based, and provide this information to the local enforcing agency. The local enforcing agency shall provide this information to the permit applicant. In addition, an enforcing agency may not issue any permit for construction, erection, alteration, modification, repair, or demolition of any building until the appropriate firesafety inspector certified pursuant to s. 633.216 has reviewed the plans and specifications required by the Florida Building Code, or local amendment thereto, for such proposal and found that the plans comply with the Florida Fire Prevention Code and the Life Safety Code. Any building or structure which is not subject to a firesafety code shall not be required to have its plans reviewed by the firesafety inspector. Any building or structure that is exempt from the local building permit process may not be required to have its plans reviewed by the local building code administrator. Industrial construction on sites where design, construction, and firesafety are supervised by appropriate design and inspection professionals and which contain adequate in-house fire departments and rescue squads is exempt, subject to local government option, from review of plans and inspections, providing owners certify that applicable codes and standards have been met and supply appropriate approved drawings to local building and firesafety inspectors. The enforcing agency shall issue a permit to construct, erect, alter, modify, repair, or demolish any building or structure when the plans and specifications for such proposal comply with the Florida Building Code and the Florida Fire Prevention Code and the Life Safety Code as determined by the local authority in accordance with this chapter and chapter 633.

(3) Except as provided in this chapter, the Florida Building Code, after the effective date of adoption pursuant to the provisions of this part, shall supersede all other building construction codes or ordinances in the state, whether at the local or state level and whether adopted by administrative regulation or by legislative enactment. However, this subsection does not apply to the construction of manufactured homes as defined by federal law. Nothing contained in this subsection shall be construed as nullifying or divesting appropriate state or local agencies of authority to make inspections or to enforce the codes within their respective areas of jurisdiction.

(4) The Florida Building Code, after the effective date of adoption pursuant to the provisions of this part, may be modified by local governments to require more stringent standards than those specified in the Florida Building Code, provided the conditions of s. 553.73(4) are met.

(5)(a) During new construction or during repair or restoration projects in which the structural system or structural loading of a building is being modified, the enforcing agency shall require a special inspector to perform structural inspections on a threshold building pursuant to a structural inspection plan prepared by the engineer or architect of record. The structural inspection plan must be submitted to and approved by the enforcing agency before the issuance of a building permit for the construction of a threshold building. The purpose of the structural inspection plan is to provide specific inspection procedures and schedules so that the building can be adequately inspected for compliance with the permitted documents. The special inspector may not serve as a surrogate in carrying out the responsibilities of the building official, the architect, or the engineer of record. The contractor's

contractual or statutory obligations are not relieved by any action of the special inspector. The special inspector shall determine that a professional engineer who specializes in shoring design has inspected the shoring and reshoring for conformance with the shoring and reshoring plans submitted to the enforcing agency. A fee simple title owner of a building, which does not meet the minimum size, height, occupancy, occupancy classification, or number-of-stories criteria which would result in classification as a threshold building under s. 553.71(12), may designate such building as a threshold building, subject to more than the minimum number of inspections required by the Florida Building Code.

(b) The fee owner of a threshold building shall select and pay all costs of employing a special inspector, but the special inspector shall be responsible to the enforcement agency. The inspector shall be a person certified, licensed, or registered under chapter 471 as an engineer or under chapter 481 as an architect.

(c) The architect or engineer of record may act as the special inspector provided she or he is on the Board of Professional Engineers' or the Board of Architecture and Interior Design's list of persons qualified to be special inspectors. School boards may utilize employees as special inspectors provided such employees are on one of the professional licensing board's list of persons qualified to be special inspectors.

(d) The licensed architect or registered engineer serving as the special inspector shall be permitted to send her or his duly authorized representative to the job site to perform the necessary inspections provided all required written reports are prepared by and bear the seal of the special inspector and are submitted to the enforcement agency.

(6) A permit may not be issued for any building construction, erection, alteration, modification, repair, or addition unless the applicant for such permit complies with the requirements for plan review established by the Florida Building Commission within the Florida Building Code. However, the code shall set standards and criteria to authorize preliminary construction before completion of all building plans review, including, but not limited to, special permits for the foundation only, and such standards shall take effect concurrent with the first effective date of the Florida Building Code. After submittal of the appropriate construction documents, the building official may issue a permit for the construction of foundations or any other part of a building or structure before the construction documents for the entire building or structure have been submitted. The holder of such permit for the foundation or other parts of a building or structure shall proceed at the holder's own risk and without assurance that a permit for the entire structure will be granted. Corrections may be required to meet the requirements of the technical codes.

(7) Each enforcement agency shall require that, on every threshold building:

(a) The special inspector, upon completion of the building and prior to the issuance of a certificate of occupancy, file a signed and sealed statement with the enforcement agency in substantially the following form: To the best of my knowledge and belief, the construction of all structural load-bearing components described in the threshold inspection plan complies with the permitted documents, and the specialty shoring design professional engineer has ascertained that the shoring and reshoring conforms with the shoring and reshoring plans submitted to the enforcement agency.

(b) Any proposal to install an alternate structural product or system to which building codes apply be submitted to the enforcement agency for review for compliance with the codes and made part of the enforcement agency's recorded set of permit documents.

(c) All shoring and reshoring procedures, plans, and details be submitted to the enforcement agency for recordkeeping. Each shoring and reshoring installation shall be supervised, inspected, and certified to be in compliance with the shoring documents by the contractor.

(d) All plans for the building which are required to be signed and sealed by the architect or engineer of record contain a statement that, to the best of the architect's or engineer's knowledge, the plans and specifications comply with the applicable minimum building codes and the applicable firesafety standards as determined by the local authority in accordance with this chapter and chapter 633.

(8) No enforcing agency may issue a building permit for construction of any threshold building except to a licensed general contractor, as defined in s. 489.105(3)(a), or to a licensed building contractor, as defined in s. 489.105(3)(b), within the scope of her or his license. The named contractor to whom the building permit is issued shall have the responsibility for supervision, direction, management, and control of the construction activities on the project for which the building permit was issued.

(9) Any state agency whose enabling legislation authorizes it to enforce provisions of the Florida Building Code may enter into an agreement with any other unit of government to delegate its responsibility to enforce those provisions and may expend public funds for permit and inspection fees, which fees may be no greater than the fees charged others. Inspection services that are not required to be performed by a state agency under a federal delegation of responsibility or by a state agency under the Florida Building Code must be performed under the alternative plans review and inspection process created in s. 553.791 or by a local governmental entity having authority to enforce the Florida Building Code.

(10) An enforcing authority may not issue a building permit for any building construction, erection, alteration, modification, repair, or addition unless the permit either includes on its face or there is attached to the permit the following statement: "NOTICE: In addition to the requirements of this permit, there may be additional restrictions applicable to this property that may be found in the public records of this county, and there may be additional permits required from other governmental entities such as water management districts, state agencies, or federal agencies."

(11) The local enforcing agency may not issue a building permit to construct, develop, or modify a public swimming pool without proof of application, whether complete or incomplete, for an operating permit pursuant to s. 514.031. A certificate of completion or occupancy may not be issued until such operating permit is issued. The local enforcing agency shall conduct its review of the building permit application upon filing and in accordance with this chapter. The local enforcing agency may confer with the Department of Health, if necessary, but may not delay the building permit application review while awaiting comment from the Department of Health.

(12) Nothing in this section shall be construed to alter or supplement the provisions of part I of this chapter relating to manufactured buildings.

(13) One-family and two-family detached residential dwelling units are not subject to plan review by the local fire official as described in this section or inspection by the local fire official as described in s. 633.216, unless expressly made subject to the plan review or inspection by local ordinance.

(14) A building permit for a single-family residential dwelling must be issued within 30 working days of application therefor unless unusual circumstances require a longer time for processing the application or unless the permit application fails to satisfy the Florida Building Code or the enforcing agency's laws or ordinances.

(15)(a) A property owner, regardless of whether the property owner is the one listed on the application for the building permit, may close a building permit by complying with the following requirements:

1. The property owner may retain the original contractor listed on the permit or hire a different contractor appropriately licensed in this state to perform the work necessary to satisfy the conditions of

the permit and to obtain any necessary inspections in order to close the permit. If a contractor other than the original contractor listed on the permit is hired by the property owner to close the permit, such contractor is not liable for any defects in the work performed by the original contractor and is only liable for the work that he or she performs.

2. The property owner may assume the role of an owner-builder, in accordance with ss. 489.103(7) and 489.503(6).

3. For purposes of this section, the term “close” means that the requirements of the permit have been satisfied.

(b) If a building permit is expired and its requirements have been substantially completed, as determined by the local enforcement agency, the permit may be closed without having to obtain a new building permit, and the work required to close the permit may be done pursuant to the building code in effect at the time the local enforcement agency received the application for the permit, unless the contractor has sought and received approval from the local enforcement agency for an alternative material, design, or method of construction.

(c) A local enforcement agency may close a building permit 6 years after the issuance of the permit, even in the absence of a final inspection, if the local enforcement agency determines that no apparent safety hazards exist.

(16)(a) A local enforcement agency may not deny issuance of a building permit to; issue a notice of violation to; or fine, penalize, sanction, or assess fees against an arms-length purchaser of a property for value solely because a building ¹permit applied for by a previous owner of the property was not closed. The local enforcement agency shall maintain all rights and remedies against the property owner and contractor listed on the permit.

(b) The local enforcement agency may not deny issuance of a building permit to a contractor solely because the contractor is listed on other building permits that were not closed.

(17) Certifications by contractors authorized under the provisions of s. 489.115(4)(b) shall be considered equivalent to sealed plans and specifications by a person licensed under chapter 471 or chapter 481 by local enforcement agencies for plans review for permitting purposes relating to compliance with the wind resistance provisions of the code or alternate methodologies approved by the commission for one and two family dwellings. Local enforcement agencies may rely upon such certification by contractors that the plans and specifications submitted conform to the requirements of the code for wind resistance. Upon good cause shown, local government code enforcement agencies may accept or reject plans sealed by persons licensed under chapter 471, chapter 481, or chapter 489. A truss-placement plan is not required to be signed and sealed by an engineer or architect unless prepared by an engineer or architect or specifically required by the Florida Building Code.

(18)(a) The Florida Building Commission shall establish, within the Florida Building Code adopted by rule, standards for permitting residential buildings or structures moved into or within a county or municipality when such structures do not or cannot comply with the code. However, such buildings or structures shall not be required to be brought into compliance with the building code in force at the time the building or structure is moved, provided:

1. The building or structure is structurally sound and in occupiable condition for its intended use;
2. The occupancy use classification for the building or structure is not changed as a result of the move;
3. The building is not substantially remodeled;
4. Current fire code requirements for ingress and egress are met;

5. Electrical, gas, and plumbing systems meet the codes in force at the time of construction and are operational and safe for reconnection; and

6. Foundation plans are sealed by a professional engineer or architect licensed to practice in this state, if required by the building code for all residential buildings or structures of the same occupancy class;

(b) The building official shall apply the same standard to a moved residential building or structure as that applied to the remodeling of any comparable residential building or structure to determine whether the moved structure is substantially remodeled. The cost of moving the building and the cost of the foundation on which the moved building or structure is placed shall not be included in the cost of remodeling for purposes of determining whether a moved building or structure has been substantially remodeled.

(19) Notwithstanding any other provision of law, state agencies responsible for the construction, erection, alteration, modification, repair, or demolition of public buildings, or the regulation of public and private buildings, structures, and facilities, shall be subject to enforcement of the Florida Building Code by local jurisdictions. This subsection applies in addition to the jurisdiction and authority of the Department of Financial Services to inspect state-owned buildings. This subsection does not apply to the jurisdiction and authority of the Department of Agriculture and Consumer Services to inspect amusement rides or the Department of Financial Services to inspect state-owned buildings and boilers.

(20)(a) A local enforcing agency, and any local building code administrator, inspector, or other official or entity, may not require as a condition of issuance of a one- or two-family residential building permit the inspection of any portion of a building, structure, or real property that is not directly impacted by the construction, erection, alteration, modification, repair, or demolition of the building, structure, or real property for which the permit is sought.

(b) This subsection does not apply to a building permit sought for:

1. A substantial improvement as defined in s. 161.54 or as defined in the Florida Building Code.
2. A change of occupancy as defined in the Florida Building Code.
3. A conversion from residential to nonresidential or mixed use pursuant to s. 553.507(3) or as defined in the Florida Building Code.
4. A historic building as defined in the Florida Building Code.

(c) This subsection does not prohibit a local enforcing agency, or any local building code administrator, inspector, or other official or entity, from:

1. Citing any violation inadvertently observed in plain view during the ordinary course of an inspection conducted in accordance with the prohibition in paragraph (a).
2. Inspecting a physically nonadjacent portion of a building, structure, or real property that is directly impacted by the construction, erection, alteration, modification, repair, or demolition of the building, structure, or real property for which the permit is sought in accordance with the prohibition in paragraph (a).
3. Inspecting any portion of a building, structure, or real property for which the owner or other person having control of the building, structure, or real property has voluntarily consented to the inspection of that portion of the building, structure, or real property in accordance with the prohibition in paragraph (a).
4. Inspecting any portion of a building, structure, or real property pursuant to an inspection warrant issued in accordance with ss. 933.20-933.30.

(d) This subsection is repealed upon receipt by the Secretary of State of the written certification by the chair of the Florida Building Commission that the commission has adopted an amendment to the

Florida Building Code which substantially incorporates this subsection, including the prohibition in paragraph (a), as part of the code and such amendment has taken effect.

(21) For the purpose of inspection and record retention, site plans or building permits may be maintained in the original form or in the form of an electronic copy at the worksite. These plans and permits must be open to inspection by the building official or a duly authorized representative, as required by the Florida Building Code.

(22)(a) A political subdivision of this state may not adopt or enforce any ordinance or impose any building permit or other development order requirement that:

1. Contains any building, construction, or aesthetic requirement or condition that conflicts with or impairs corporate trademarks, service marks, trade dress, logos, color patterns, design scheme insignia, image standards, or other features of corporate branding identity on real property or improvements thereon used in activities conducted under chapter 526 or in carrying out business activities defined as a franchise by Federal Trade Commission regulations in 16 C.F.R. ss. 436.1, et. seq.; or

2. Imposes any requirement on the design, construction, or location of signage advertising the retail price of gasoline in accordance with the requirements of ss. 526.111 and 526.121 which prevents the signage from being clearly visible and legible to drivers of approaching motor vehicles from a vantage point on any lane of traffic in either direction on a roadway abutting the gas station premises and meets height, width, and spacing standards for Series C, D, or E signs, as applicable, published in the latest edition of Standard Alphabets for Highway Signs published by the United States Department of Commerce, Bureau of Public Roads, Office of Highway Safety.

(b) This subsection does not affect any requirement for design and construction in the Florida Building Code.

(c) All such ordinances and requirements are hereby preempted and superseded by general law. This subsection shall apply retroactively.

(d) This subsection does not apply to property located in a designated historic district.

History.—s. 10, ch. 74-167; s. 4, ch. 77-365; s. 10, ch. 83-160; s. 1, ch. 83-352; s. 2, ch. 84-24; s. 3, ch. 84-365; s. 2, ch. 85-97; s. 2, ch. 86-135; s. 2, ch. 87-287; s. 5, ch. 87-349; s. 2, ch. 88-142; s. 1, ch. 88-378; s. 1, ch. 91-7; s. 4, ch. 93-249; ss. 57, 260, ch. 94-119; s. 7, ch. 94-284; s. 461, ch. 94-356; s. 72, ch. 95-144; s. 2, ch. 95-379; s. 14, ch. 96-298; s. 73, ch. 96-388; s. 1175, ch. 97-103; ss. 48, 49, ch. 98-287; ss. 82, 83, 84, 135, ch. 2000-141; ss. 27, 34, 35, 37, ch. 2001-186; ss. 2, 3, 4, 6, ch. 2001-372; s. 666, ch. 2003-261; s. 10, ch. 2005-147; s. 36, ch. 2010-176; s. 1, ch. 2011-82; s. 73, ch. 2012-5; s. 15, ch. 2012-13; s. 150, ch. 2013-183; s. 16, ch. 2013-193; s. 126, ch. 2014-17; s. 22, ch. 2014-154; ss. 19, 39, ch. 2016-129; s. 36, ch. 2017-3; s. 3, ch. 2017-149; s. 5, ch. 2019-75; s. 11, ch. 2019-86.

¹**Note.**—The word “was” following the word “permit” was deleted by the editors for clarity.