

CR A, CR B, AND CR K TYPE CURB RAMPS

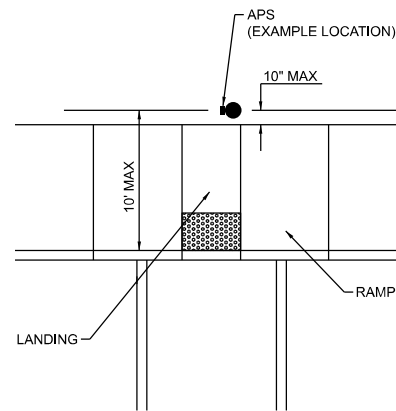

CR C TYPE CURB RAMPS

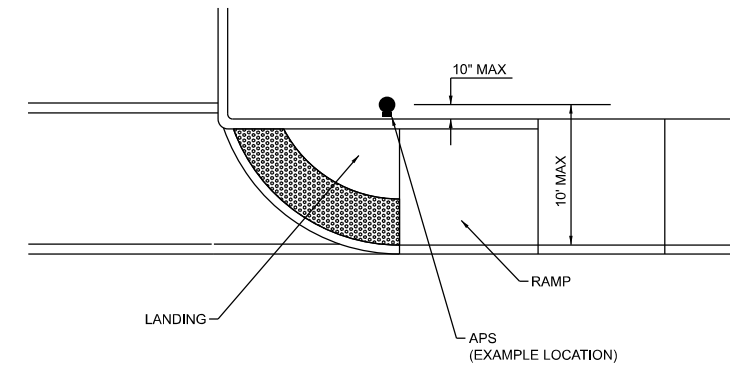

CR D, CR F, CR G, AND CR H TYPE CURB RAMPS

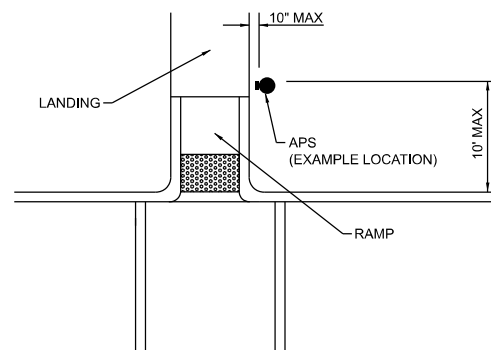

CR E TYPE CURB RAMPS

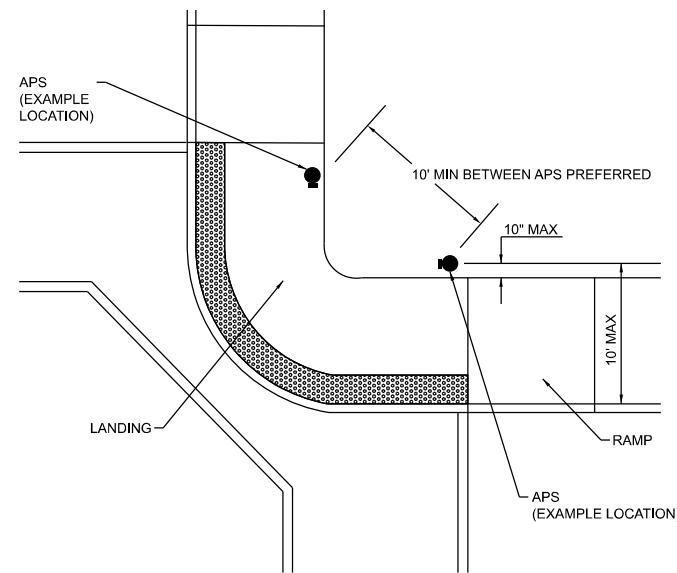

CR L TYPE CURB RAMPS

NOTES:

1. CURB RAMP TYPES REFERENCED ARE FROM LATEST FDOT STANDARDS.
2. WHERE THERE ARE CONSTRAINTS THAT MAKE IT IMPRACTICAL TO PLACE THE PEDESTRIAN PUSHBUTTON BETWEEN 1.5' AND 6' FROM THE EDGE OF CURB, SHOULDER, OR PAVEMENT, IT SHOULD NOT BE FURTHER THAN 10' FROM THE EDGE OF CURB, SHOULDER OR PAVEMENT.
3. WHERE THERE ARE CONSTRAINTS ON A PARTICULAR CORNER THAT MAKE IT IMPRACTICAL TO PROVIDE 10' SEPARATION BETWEEN THE TWO PEDESTRIAN PUSHBUTTONS, THE PUSHBUTTONS MAY BE PLACED CLOSER TOGETHER OR ON THE SAME POLE.

REVISIONS	
DATE	DESCRIPTION
6-04-21	N/A



**PUBLIC WORKS DEPARTMENT**  
TRAFFIC ENGINEERING DIVISION

**RECOMMENDED PEDESTRIAN PUSHBUTTON  
LOCATIONS FOR VARYING CURB RAMPS**

**SHEET  
NO.**

**1**